

CAKJ-XHB-8X~48X Microcomputer Central Signal Alarm Device

1, OVERVIEW

CAKJ-XHB separate micro computer central signal alarm device is a centralized management device that designed for Power station and Transformer substation signal system. The device that extensively used in electric, petrochemical, chemical industry, metallurgy and coal industry, is a high intelligent product that automatic monitoring and signal alarm for power and industrial.

2, FUNCTIONAL CHARACTERISTICS

- 1) The panel includes digital display and power on self test (POST).Integrated design.
- 2) Provide with test (light test), confirm (accept), return (reset) , signal recall and clear function. With function buttons.
- 3) Provide with manual and automatic accept function, automatic accept time limit (0-200s) able to set.
- 4) Signal alarm type able to distinguish: accident signal S, warning signal Y, position signal P, all available to set.
- 5) Alarm window color: able to choose red, white, yellow, green, accord to signal alarm type, separated by color is more arresting and visually.
- 6) Input signal status: switch contact (h), switch hold contact (E), and pulse hold contact (C). (Note)
- 7) The input signal is normally open and normally closed. For each signal, the normally open and normally closed alarm (default) can be set, and the normally closed variable normally open alarm can be set.
- 8) Signal delayed alarm: 0-9999ms delay alarm time limit able to set.
- 9) Device bring with buzzer, when accident happy it sounds “bi---”, warning signal sounds short beep “bi, bi, bi, bi”, position signal doesn’t sound.
- 10) Device with accident and warning signal alarm output contact, able to activate electric bell, enhance the alarm effect.
- 11) With remote signal output contacts, connect to other devices or as an accident stop signal.
- 12) It has the device power disappearance contact output.
- 13) Provide with digital communication output, RS485 serial communication contact, MODBUS communication protocol.

◆Note: Explanation of input signal status and alarm procedures

When“h” is selected as the input signal state (default), the workflow is as follows:

Line	Run	Button	Alarm status	Light plate	Sound status	Remark
1	Normal	-	Normal	Off	Silent	
2A	Abnormal	-	Alarm	Flash	Sound	Alarm
2B	Abnormal	Silence	Alarm	Flash	Silent	Alarm hold
3A	Abnormal	Confirm	Confirmed	Bright	Silent	Alarm hold
3B	Normal		-	To line 4		Instant alarm
4	Normal	-	Normal	Off	Silent	Automatic reset

When the state of the input signal is "C" or "E", the work flow is as follows:

Line	Run	Button	Alarm status	Light plate	Sound status	Remark
1	Normal	-	Normal	Off	Silent	
2A	Abnormal	-	Alarm	Flash	Sound	Alarm
2B	Abnormal	Silence	Alarm	Flash	Silent	Alarm hold
3A	Abnormal/Normal	Confirm	Confirmed	Bright	Silent	Alarm hold
3B	Normal to abnormal	-	Alarm	To line 2A		Restart alarm
4A	Abnormal	Reset	-	To line 3A		Alarm hold
4B	Normal		Normal	Off	Silent	Manual reset

Note: The signal is normal if the signal is not alarmed, and the signal abnormal is if it is alarmed

3, CONMENT TECHNIQUE REQUIREMENT

- 1.Working power supply: AC or DC 80-265V wide voltage, DC24V Optional
- 2.Signal capacity: 8、 12、 16、 24、 32、 48 Circuits
- 3.Input signal method: Normally open active dry contact, or active contact.
- 4.Alarm window: Flash window measures are 53×28 or 30×30, colors: red, green, yellow, white to choose.
- 5.Alarm output: Alarm window flash, buzzer or sound equipment sounds.
- 6.Alarm sound: Buzzer beeps 60DB; we provide intensive sound equipment CAKJ-DL electric bell, CAKJ-DD electric whistle, Or CA-XXS-YX2 Electronic audio.
- 7.Contact output: 5 relay contact outputs, corresponding to power disappearance, warning alarm, accident alarm,

pre-emptive remote communication (follow-up), accident remote communication (follow-up).

8.Contact capacity: AC250V, 3A pure resistance load, DC220V, 0.125A inductive load.

9.Function setup: touch button setting, 5 digits display.

10.Power consume: The whole device consumed no greater than 30W.

11.Communication contact: Standard RS485 serial communication contact, MODBUS communication protocol.

12.Insulation resistance: no less than 100 MΩ in-between input-output-power supply-cage.

13.Power frequency voltage: in-between input- output-power supply-cage, able to bear the tests of 2kV, 1min, 5mA, 50/60HZ, no signs of flashover and breakdown.

14.Capacity of resisting disturbance: able to bear 1 MHz and 100 kHz high frequency interference of attenuated shock wave. First half wave voltage amplitude common mode is 2.5 kV, different mode voltage is 1.0 kV, the product shouldn't appear unwanted operation or failure of operate.

15.Environment condition: surrounding temperature -10°C~60°C; surrounding humidity no greater than 90%.

16.Weight: 2.5 kg.

4, DEVICE SETUP

Press "SET" set button, press "←" to move, "↑" to add 1, insert PIN (8080) into setup mode. Recording to menu indication press "SET" to turn pages for function setting. (Edition no. v1.1)

Symbol	Setting content	Operate	Setting	Instruction
C 0	Insert PIN	"←""↑"	PIN	8080
n. n	total loops no.	"SET"	24	n this is factory setting
└. 30	Setting auto confirm time	"←""↑"	0~200s	30s ("0" not confirm automatically)
d. 20	Setting signal delay alarm time	"←""↑"	0-9999ms	20, 20ms,
y--A	Alarm audio setting	"↑"selected	A, F, d, n	A(A audio all on, F buzzer only, d external audio only, n audio all off)
S. 1	comm. adds.	"←""↑"	0~255	1(communication add. is the only one)
b.9600	Communication Baud rate	"↑"selected	9600/4800	9600
J. 0	Memory signal clear	"←""↑"	Clear PIN	1001(correct pin clear record)
L01-y	Setting 01 type	"↑"selected,	y, S, P	y(the device default all signals are "y" warning signals, recording every single signal type, press "↑" to choose "S" failure signal, press "↑"to choose "P" location signal, while finish, press "←" to turn pages, setting signal types one by one.
L02-y	Setting 02 type	"←"turn pages,		
----	-----	setting signal		
Ln-y	Setting n type	type one by one		
E01-h	Setting 01 status	"↑"selected,	h, C,E	h (h device default switch contact) , press "↑"to choose "C" pulse type retaining contact, press"↑" to choose "E" switch retaining contact, while finish, press "←" to turn pages, setting signal type one by one)
E02-h	Setting 02 status	"←"turn pages,		
----	-----	setting signal		
En-h	Setting n status	input type one by one		
F01-o	Setting 01 op/co	"↑"selected,	o , c	o (Device by default, Normally open contacts closed alarm) , press the "↑" choose "c" Normally closed contacts open alarm. press← to flip pages, set normally open/closed alarm them one by one.
F02-o	Setting 02 op/co	"←"turn pages,		
----	-----	setting signal		
Fn-o	Setting n op/co	open/closed one by on		

while setting finish or no setting press "SET" button to save and exit, restore to normal alarm condition.

◆Signal unified setting table; press "SET" to enter the setting, press "←" to shift, press "↑" to add 1, after entering the code, press "SET" to complete the setting and return

Enter code	Set 1-n signal alarm type	Enter code	Set 1-n signal input status
C1101	Unified settings for accident signals S	C1104	Uniformly set as switch contacts h
C1102	Uniformly set as a warning signal y	C1105	Uniformly set as pulse contacts C
C1103	Uniformly set as position signal P	C1106	Uniformly set to keep contacts E

Note: This setting is convenient for the user to set all signals to one type or state on site, do not operate easily.

★Light word plate alarm name printing transparent paper or light board replacement diagram

53x28

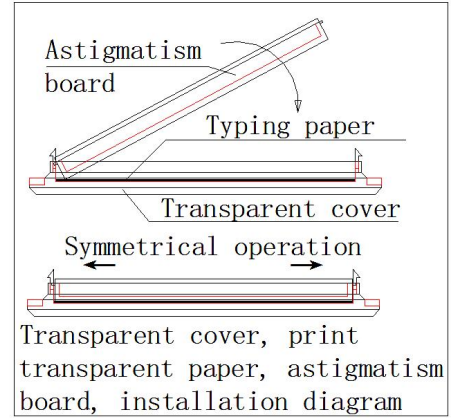
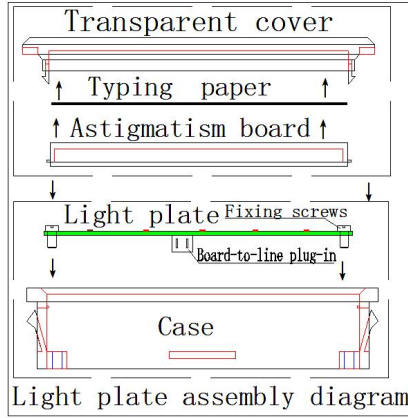
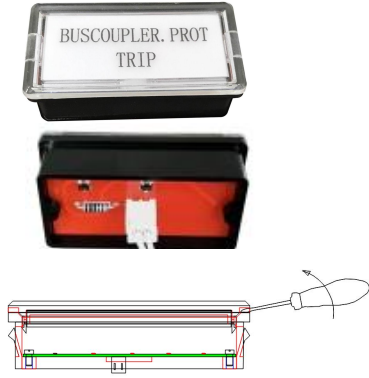

Method of opening the transparent cover

30x30

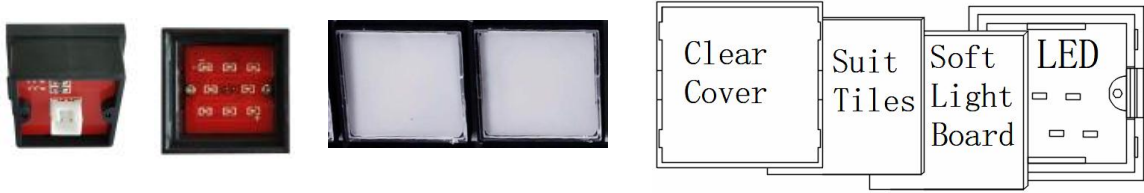

5, DEVICE ALARM AND TESTING

- 1) POST (power on self test), when device power on, digital display window on device panel shows in sequence **【0.0.0.0.0】 【1.1.1.1.1】 ... 【7.7.7.7.7】 【8.8.8.8.8】** alarm window all light **【9.9.9.9.9】** alarm window all light scroll display **【C- n L】** (for power indicate). POST finish. "n" is the total number of circuits of the alarm device.
- 2) Press "test" button, all alarm window flash, buzzer sounds, output audio equipment act. Release test button, return to monitoring status.
- 3) When signal alarm, recording alarm window flash, and buzzer sounds, output audio equipment act to start electric whistle sound. Digital display window shows recording loop number.
- 4) Press "accept" button (or 0-200s affirm automatically), alarm window turns from flash to light, buzzer silence, output audio contact return, electrical whistles and bell silence.
- 5) When signal return, switch type contact input signal recording alarm window lights off. Retention type contact input signal alarm window remain alarm, require manual reset (press "reset" button), and alarm window lights off.
- 6) Long press "recall" button, alarmed signals will shine one by one which followed alarm sequence by FILO (first in last out) rules. At the same time LED display shows alarmed loop, maximum 200 signals can be recalled, and alarm signals have priority.

6, Model specifications

Model	Alarm loop	Series code	signal type	Detailed description
CAKJ-XHB				Changan integrated signal alarm device
	-8			8 Loop alarm signals (8 alarm light plates)
	-12			12 Loop alarm signals (12 alarm light plates)
	-16			16 Loop alarm signals (16 alarm light plates)
	-24			24 Loop alarm signals (24 alarm light plates)
	-32			32 Loop alarm signals (32 alarm light plates)
	-48			48 Loop alarm signals (64 alarm light plates)
		X		X series size, Standard type
		X2 or X3		X series non-standard improved type (size change)
			blank	Alarm signal is passive dry contact signal input
			-A	Alarm signal is active voltage signal input (DC220V, DC110V, etc., specified when ordering)

Example: CAKJ-XHB-32X Central signal alarm device (32 Loop passive signal input alarm)
 CAKJ-XHB-32X-A Central signal alarm device (32-Loop active signal input alarm, DC220V)

7, System wiring diagram

◆ Basic control operation circuit

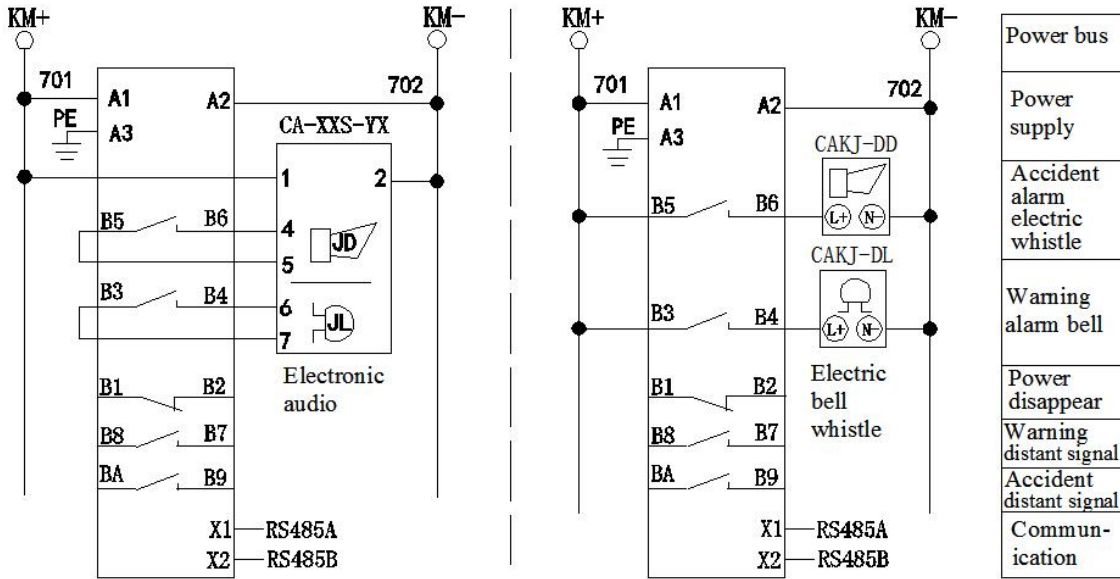

8,12,16,24 button and external button function

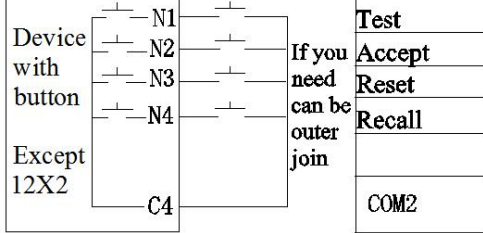

32,48 button and external button function

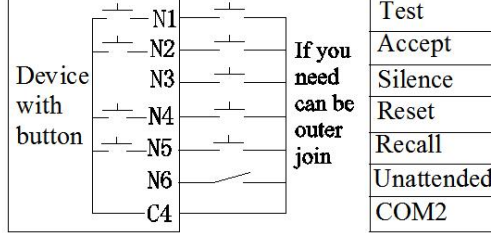

◆ Signal input circuit wiring diagram

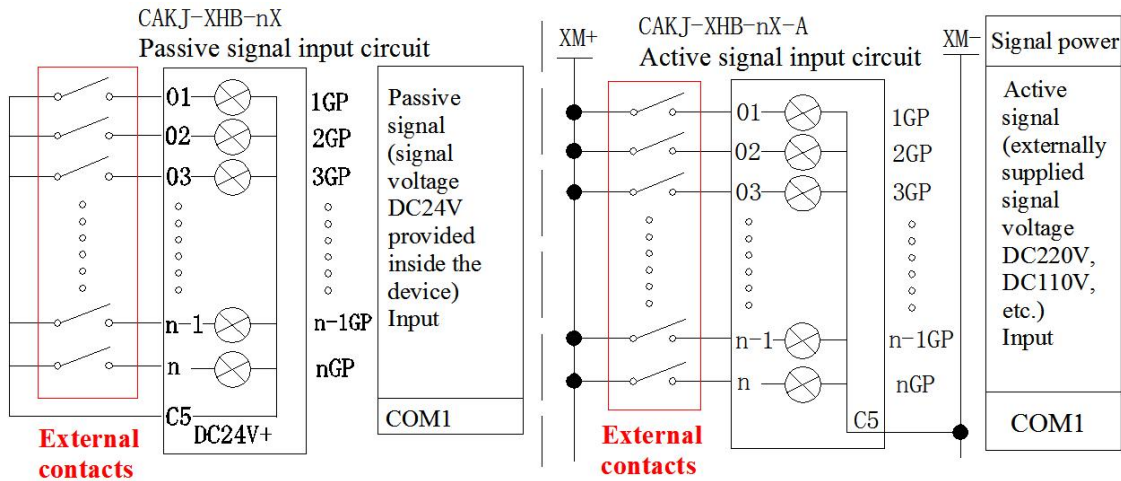

◆ Schematic diagram of passive dry contact and active voltage signal input

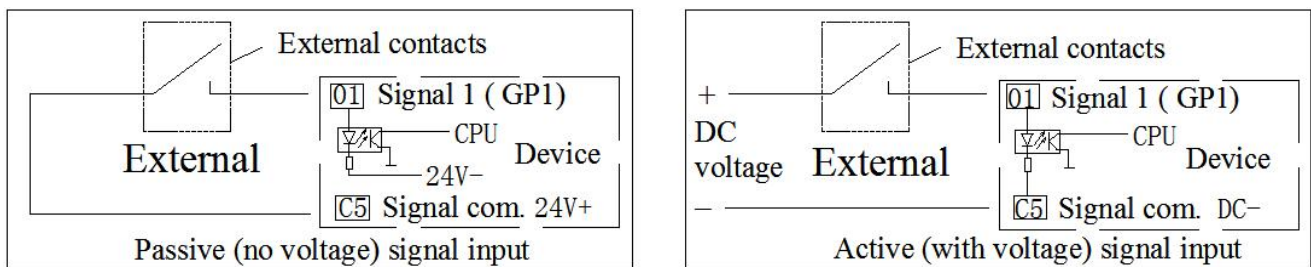

8, Detailed description of signal device

◆8-circuit central signal alarm device

1. Model and specifications

Product Model	Alarm Circuit	Input Signal Type	Signal Voltage	Power supply
CAKJ-XHB-8X	8 Circuits	Passive dry contact signal input	not have	AC or DC
CAKJ-XHB-8X-A	8 Circuits	Active voltage signal input	DC110V,DC220V etc	80-265V

2. 8X appearance graphics



3. 8X appearance and installation hole size

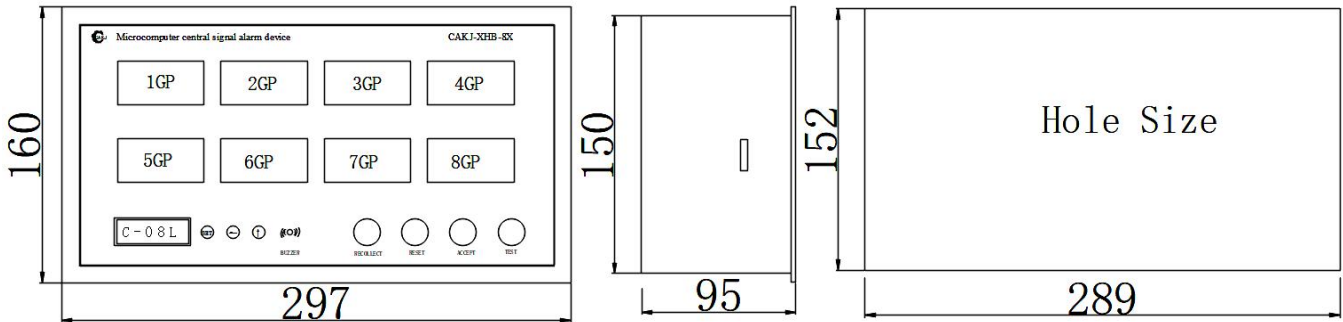

4. 8X wiring and location diagram

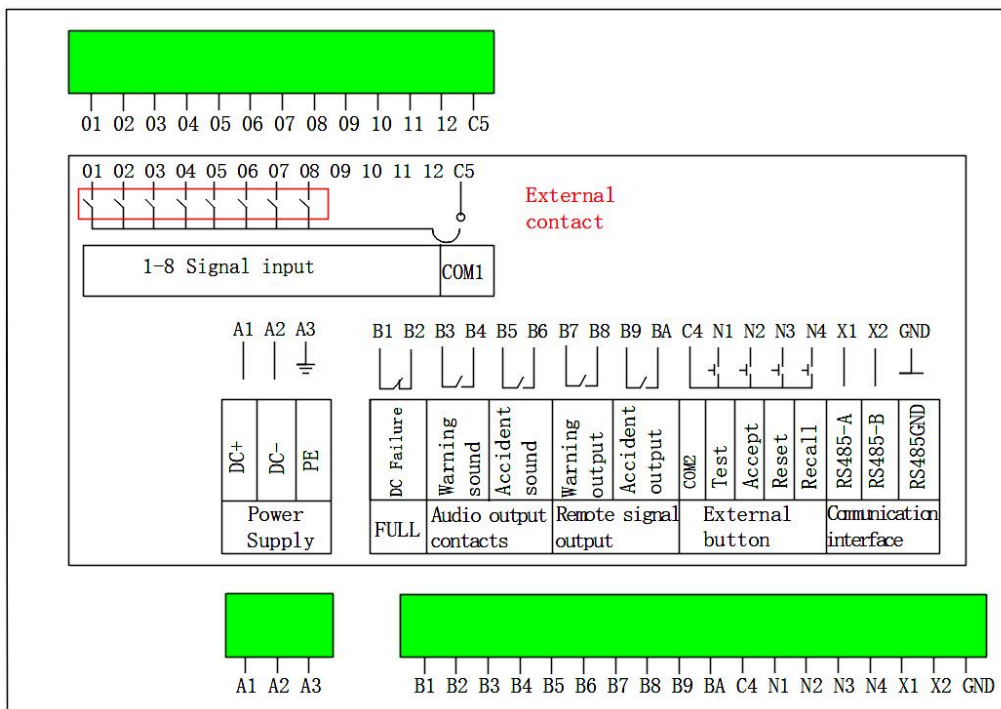

Note: External buttons: common, test, confirm, reset, recall, and audio output terminals. Multiple sets of devices can be connected in parallel, sharing one set of buttons and audio. The corresponding terminal block can be installed in any combination. Note that the buttons or switches connected in parallel must be passive dry contacts.

◆ 12-circuit central signal alarm device

1. Model and specifications

Product Model	Alarm Circuit	Input Signal Type	Signal Voltage	Power supply
CAKJ-XHB-12X	12 Circuits	Passive dry contact signal input	not have	AC or DC
CAKJ-XHB-12X-A	12 Circuits	Active voltage signal input	DC110V,DC220V etc	80-265V

2. 12X appearance graphics



3. 12X appearance and installation hole size

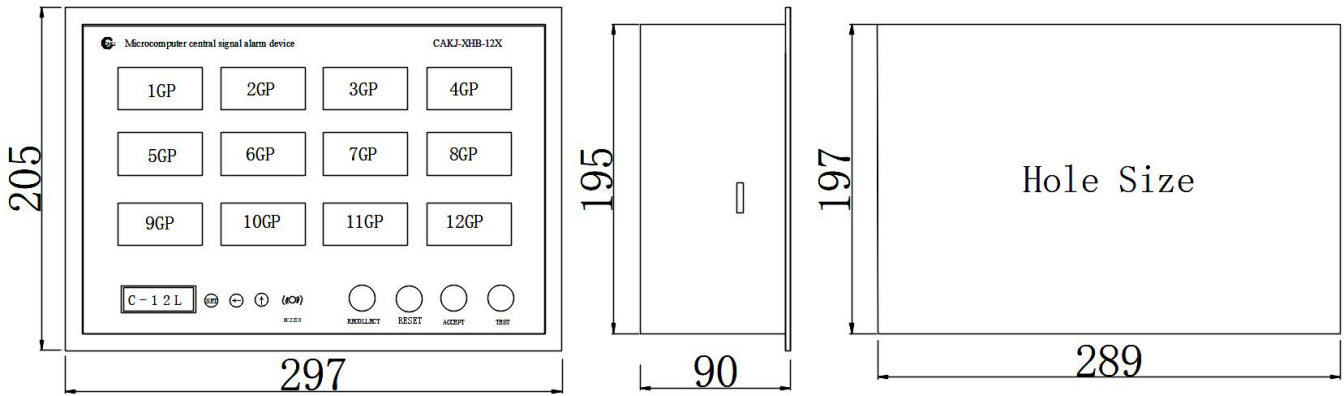

4. 12X wiring and location diagram

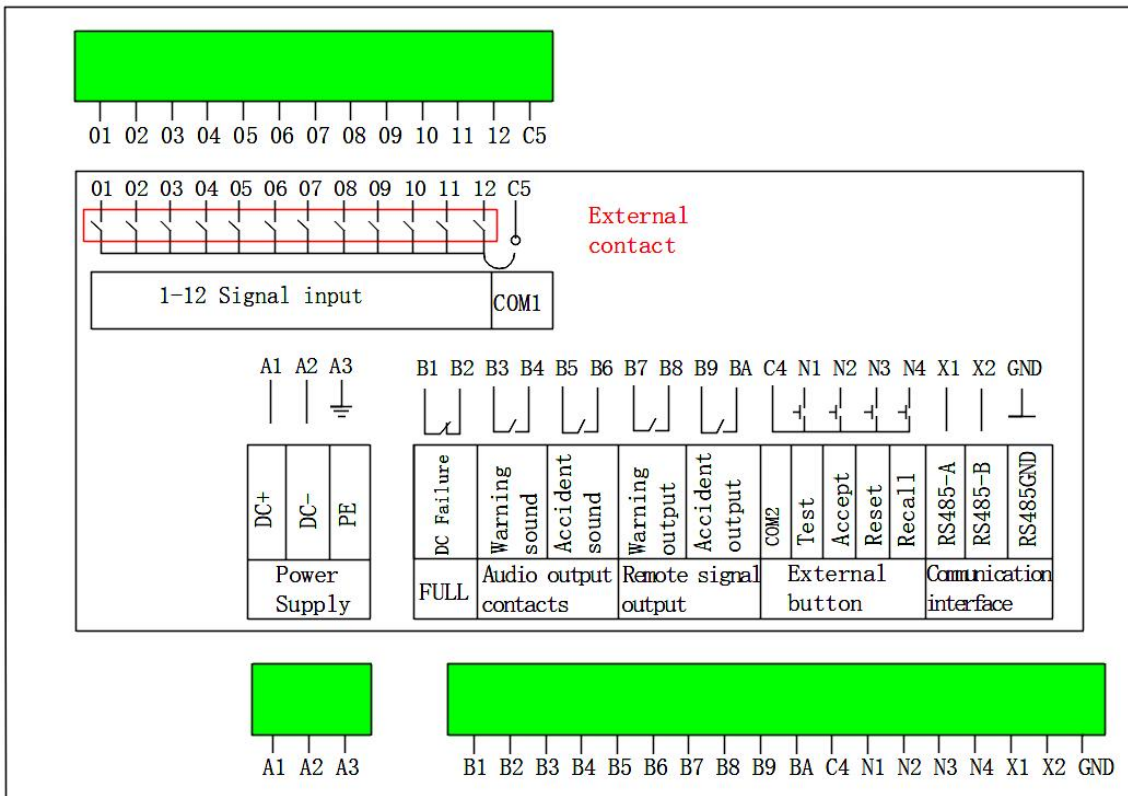

◆ 16-circuit central signal alarm device

1. Model and specifications

Product Model	Alarm Circuit	Input Signal Type	Signal Voltage	Power supply
CAKJ-XHB-16X	16 Circuits	Passive dry contact signal input	not have	AC or DC 80-265V
CAKJ-XHB-16X-A	16 Circuits	Active voltage signal input	DC110V,DC220V etc	

2. 16X appearance graphics



3. 16X appearance and installation hole size

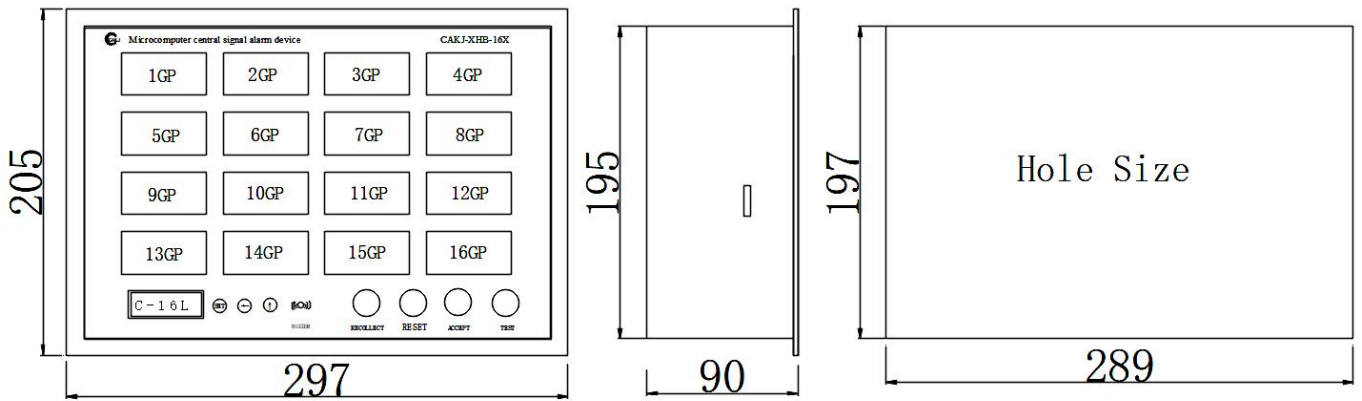

4. 16X wiring and location diagram

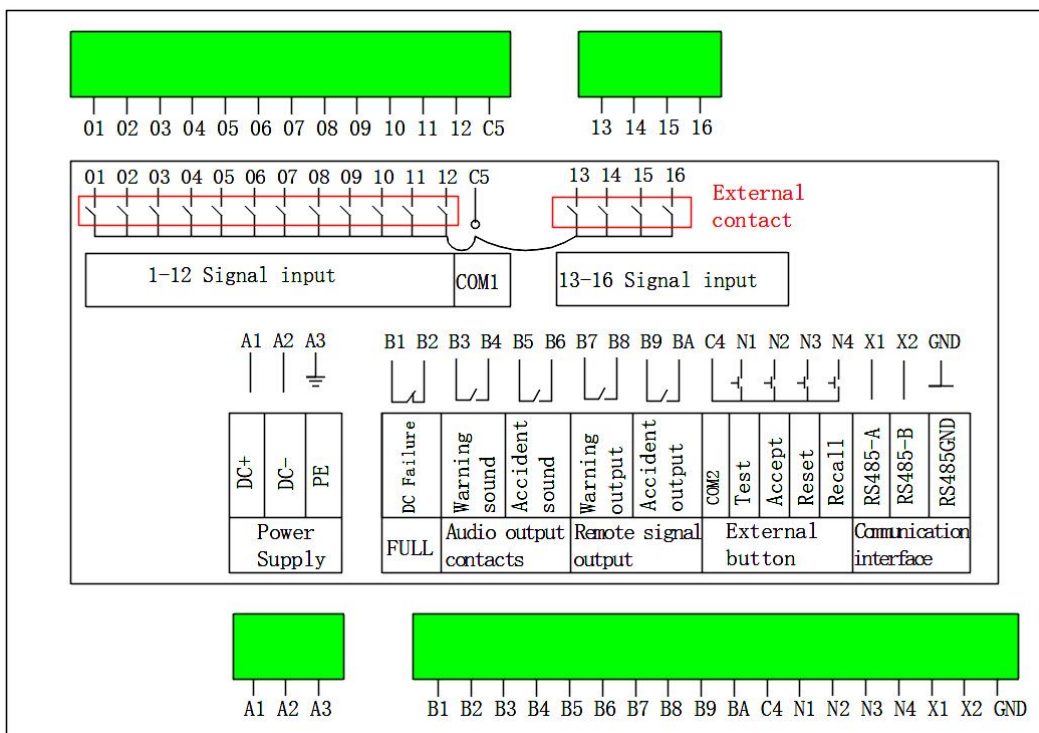

◆ 24-circuit central signal alarm device

1. Model and specifications

Product Model	Alarm Circuit	Input Signal Type	Signal Voltage	Power supply
CAKJ-XHB-24X	24 Circuits	Passive dry contact signal input	not have	AC or DC 80-265V
CAKJ-XHB-24X2	24 Circuits	Passive dry contact signal input	not have	
CAKJ-XHB-24X3	24 Circuits	Passive dry contact signal input	not have	
CAKJ-XHB-24X-A	24 Circuits	Active voltage signal input	DC110V,DC220V etc	
CAKJ-XHB-24X2-A	24 Circuits	Active voltage signal input	DC110V,DC220V etc	
CAKJ-XHB-24X3-A	24 Circuits	Active voltage signal input	DC110V,DC220V etc	

2. 24X appearance and installation hole size

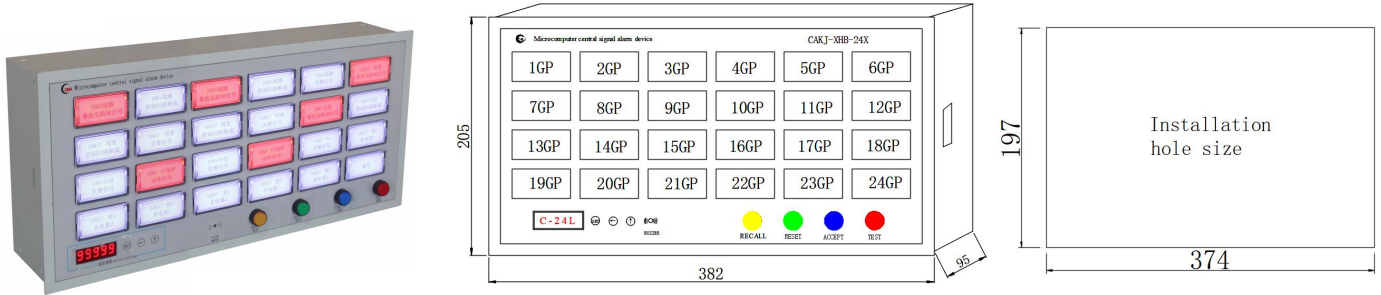

3. 24X2 appearance and installation hole size

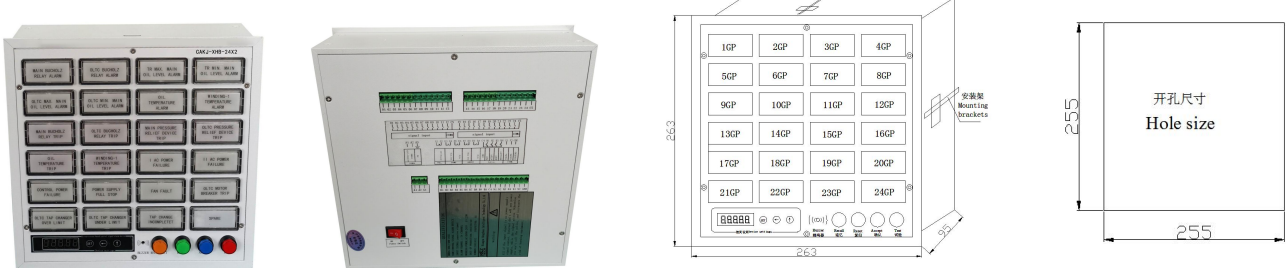

4. 24X3 appearance and installation hole size

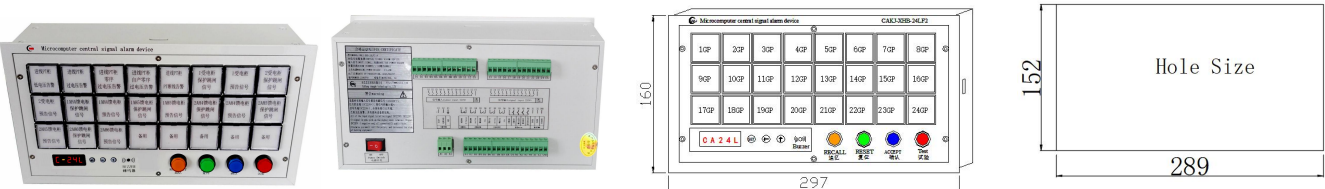

5. Wiring and location diagram

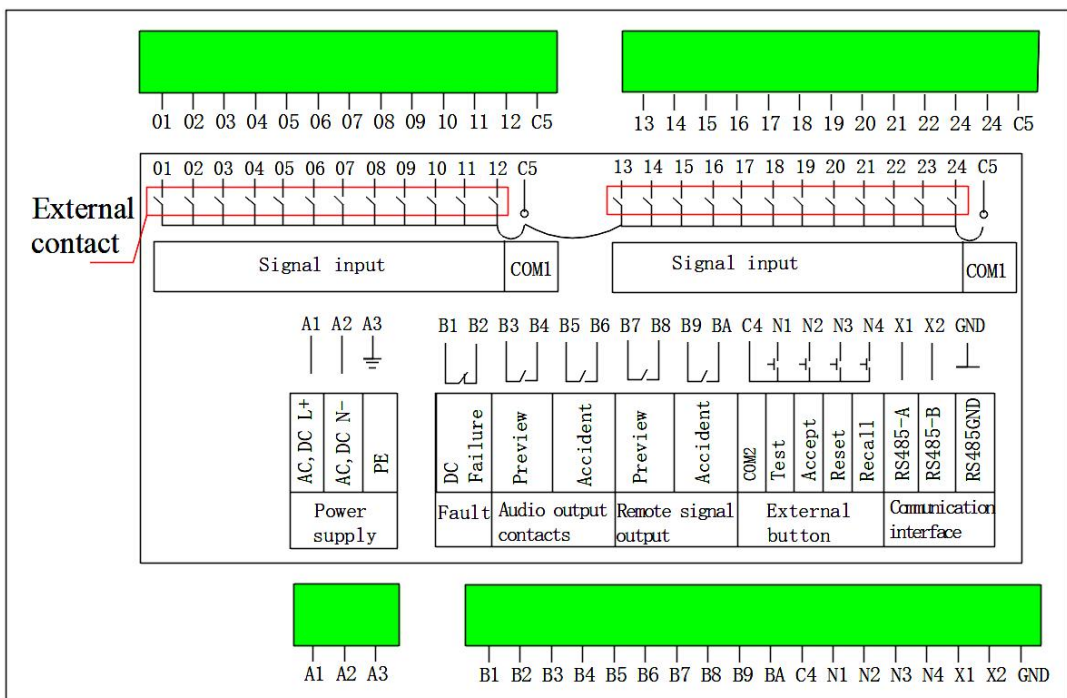

◆ 32-circuit central signal alarm device

1. Model and specifications

Product Model	Alarm Circuit	Input Signal Type	Signal Voltage	Power supply
CAKJ-XHB-32X	3 Circuits	Passive dry contact signal input	not have	AC or DC 80-265V
CAKJ-XHB-32X2	32 Circuits	Passive dry contact signal input	not have	
CAKJ-XHB-32X-A	32 Circuits	Active voltage signal input	DC110V,DC220V etc	
CAKJ-XHB-32X2-A	32 Circuits	Active voltage signal input	DC110V,DC220V etc	

2. 32X appearance and installation hole size

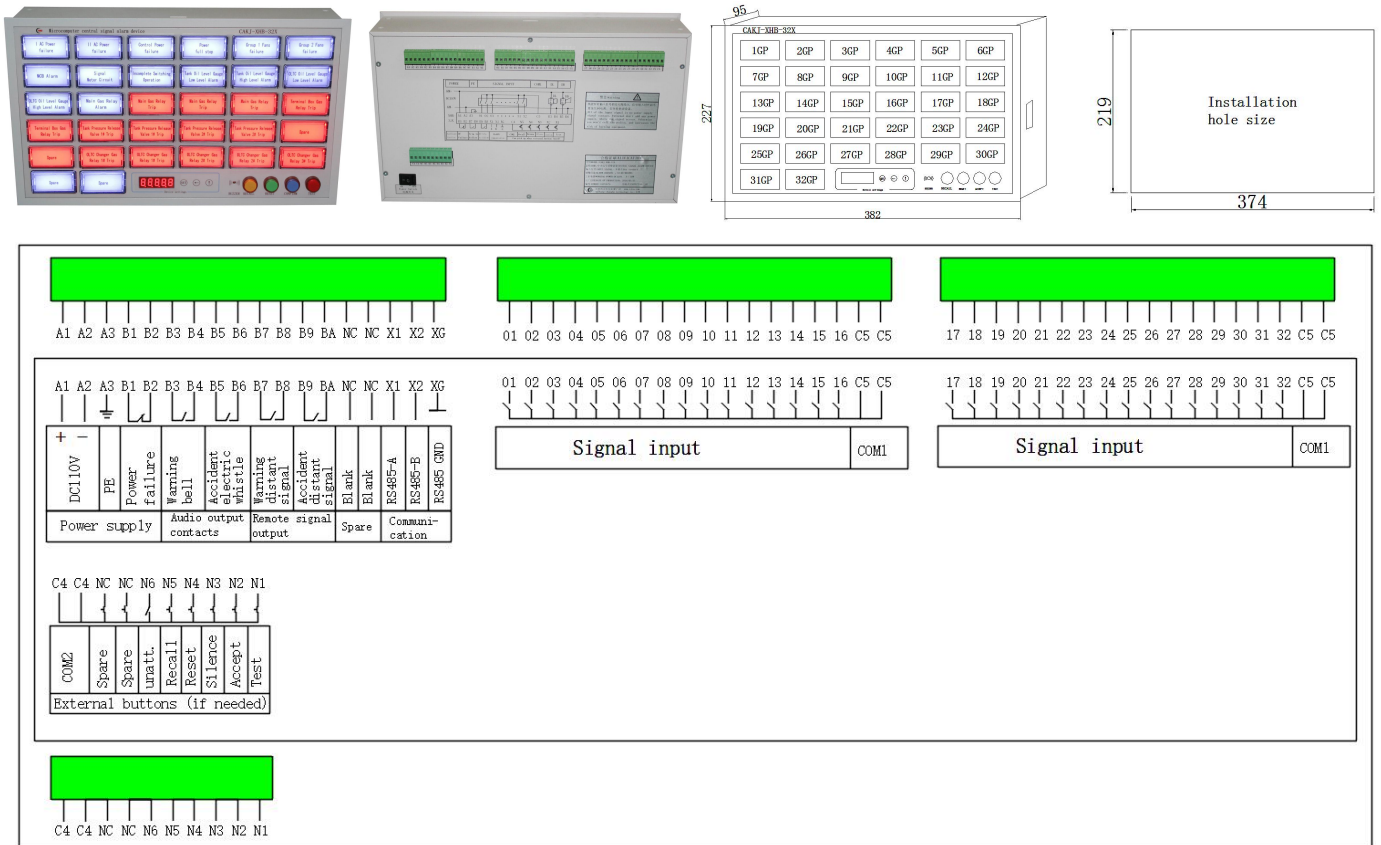

3. 32X2 appearance and installation hole size

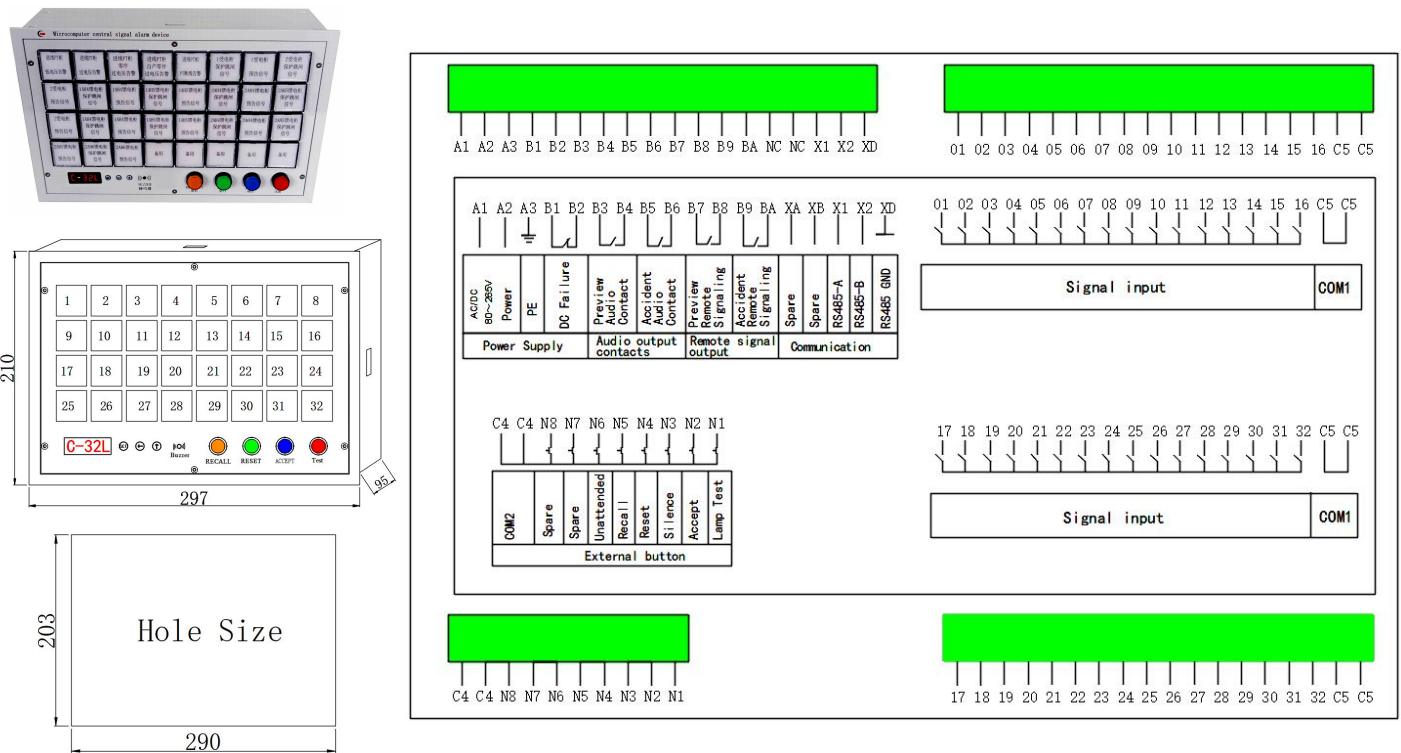

◆ 48-circuit central signal alarm device

1. Model and specifications

Product Model	Alarm Circuit	Input Signal Type	Signal Voltage	Power supply
CAKJ-XHB-48X	48 Circuits	Passive dry contact signal input	not have	AC or DC 80-265V
CAKJ-XHB-48X2	48 Circuits	Passive dry contact signal input	not have	
CAKJ-XHB-48X-A	48 Circuits	Active voltage signal input	DC110V,DC220V etc	
CAKJ-XHB-48X2-A	48 Circuits	Active voltage signal input	DC110V,DC220V etc	

2. 48X appearance and installation hole size

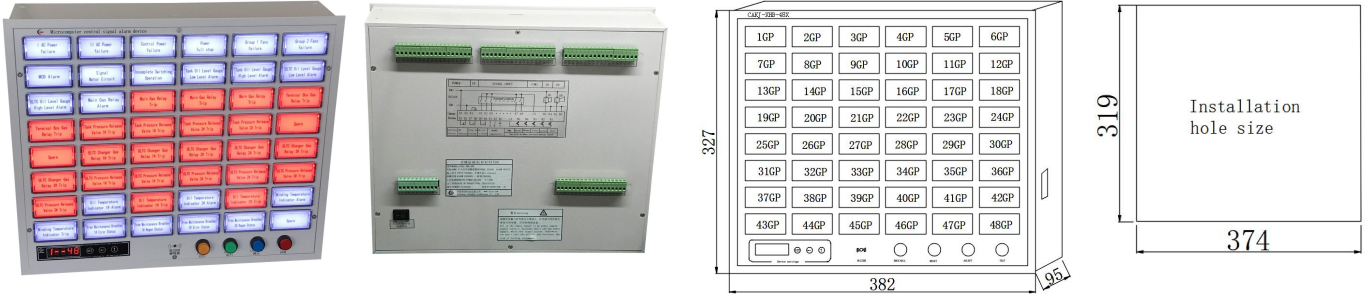

3. 48X2 appearance and installation hole size

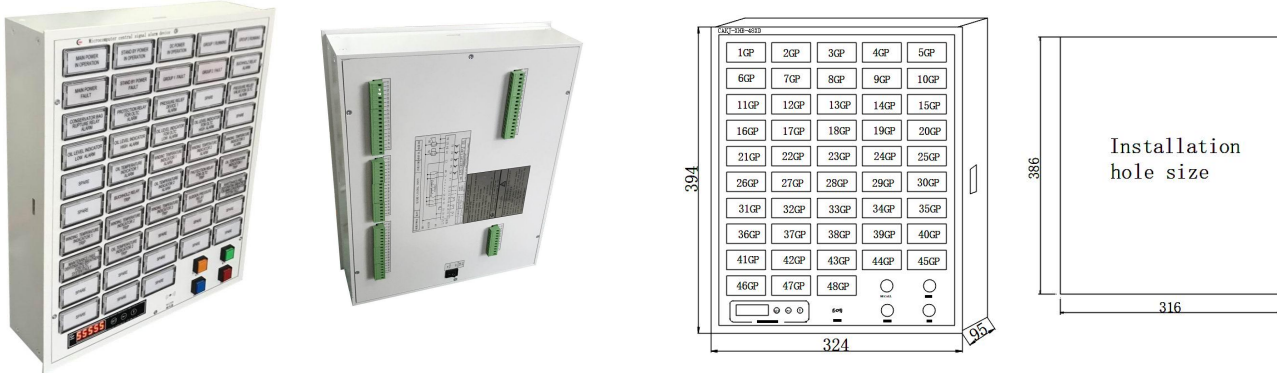

4. Wiring and location diagram

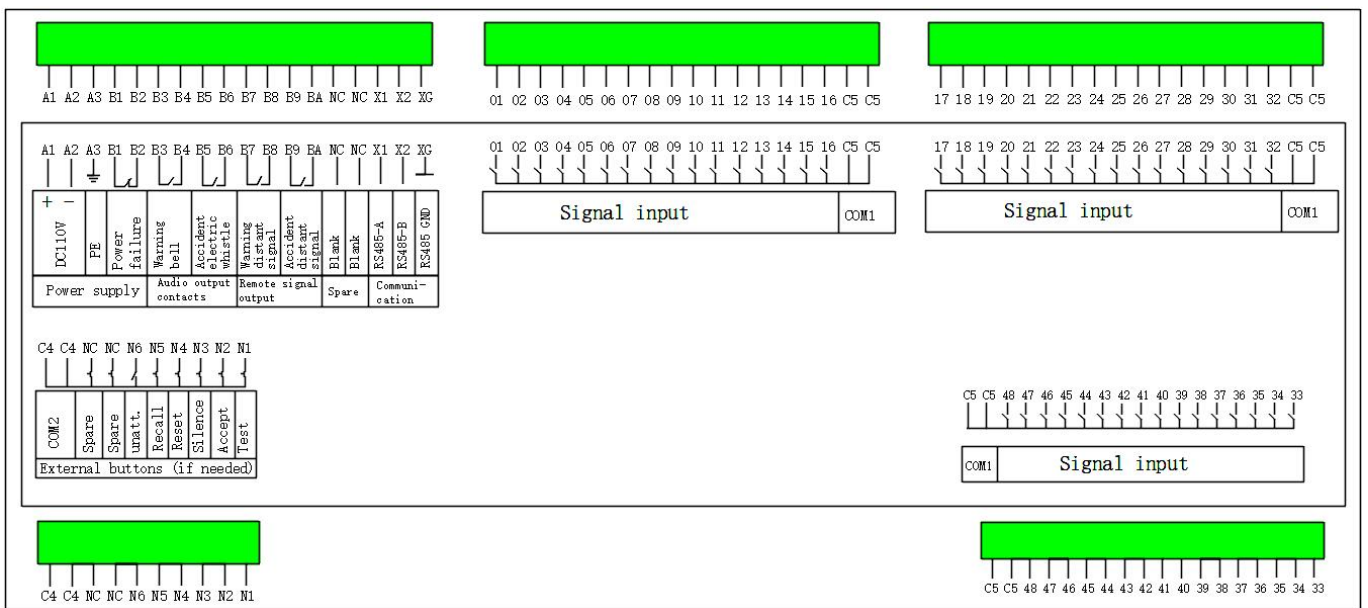

CAKJ-DL, DD Electronic bell and whistle (optional)

1、 Overview

CAKJ-DL, DD electronic bell and whistle, is a low-power, non-interference, and high-volume electronic alarm device designed for central signal alarm in the power system. Using a microcontroller to simulate the sound spectrum of an electromagnetic bell and whistle, its sound is 98% similar to that of an electromagnetic bell and whistle.

2、 Model specifications

CAKJ-DL Electronic Bell

CAKJ-DD Electric whistle

3、 Technical parameters

Working power supply: AC, DC80~265V, wide voltage AC/DC universal,
DC24V specified when ordering

Power consumption: not more than 3VA

Sound volume: 120DB

Electric ringtone: beeping, continuous sound

Electric flute sound: beep, uninterrupted sound

Working mode: Power on sounds, power off sounds silent Dielectric performance

Isolation voltage: Input terminal to ground 3000V, 1min

Insulation resistance: > 100M Ω.

Anti interference ability: The product can withstand the electrical fast transient pulse group immunity test with a test level of 4 specified in Chapter 5 of GB/T 17626.4-2008

Applicable environment: temperature -25~55 °C, humidity not exceeding 90% RH

Mean time between failures: not less than 50000h

4、 External dimensions and wiring

External dimensions: 80x110x100mm

Installation method: 35mm guide rail installation

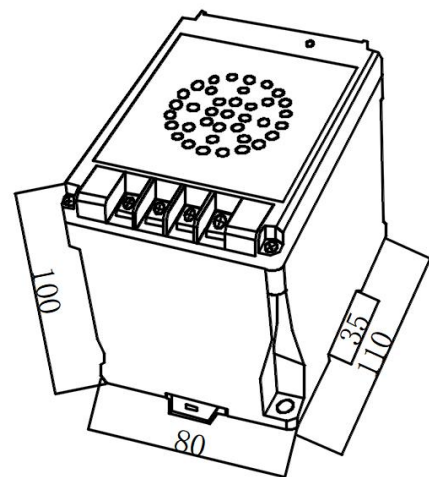
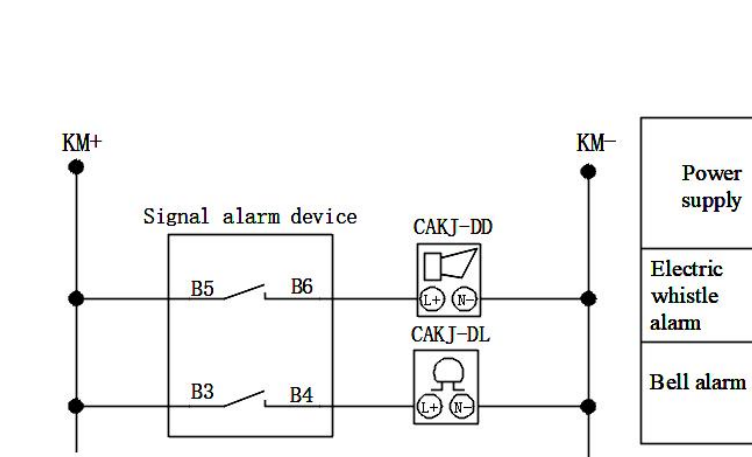

Electronic audio system (optional)

1、 Overview

CA-XXS-YX2 electronic audio system is a low-power, non-interference, and high-volume electronic alarm device designed for central signal alarms in power systems. Using a microcontroller to simulate the frequency spectrum of electronic audio systems (fire and rescue sounds), electric bells, and electric horns, its sound is 98% similar to that of fire, rescue, electromagnetic electric bells, and electric horns. It has dual speakers and dual tones, and the tone volume can be adjusted.

2、 Technical parameters

Working power supply: AC, DC80-265V, wide voltage AC/DC universal, DC24V specified when ordering

Power consumption: not exceeding 5VA

Adjustable volume: 120DB high and 60DB low can be selected by pressing the "volume" button

Tone options: Electronic audio system, electric bell and flute sound can be selected by pressing the "Tone" button

Alarm circuit: 2 signal inputs, accident audio contact and warning audio contact.

Working mode: Connect the signal to sound, disconnect the signal silently.

Sound test: Press the test button, the accident and warning will sound simultaneously, and the indicator light will light up.

Indicator lights: 6 LEDs, power, test, tone, volume, accident, and warning.

Among them, the tone LED (not on - electronic sound system, on - electric bell and whistle),

Volume LED (off bass, on treble)

Button: 3 buttons for testing, tone, and volume.

Dielectric performance

Isolation voltage: Input terminal to ground 3000V, 1 minute

Insulation resistance: > 100M Ω.

Anti interference capability: The product can withstand the requirements specified in Chapter 5 of GB/T 17626.4-2008

Test level 4 electrical fast transient pulse group immunity test

Applicable environment: Temperature -25~55 °C, humidity not exceeding 90% RH

Mean time between failures: not less than 50000h

3、 Installation and wiring

Fixed with brackets or suspended behind the disc with accessories for hole embedding

External dimensions: 210X135X92

Opening size: 202X127

