

CAKJ-XHB-16L~192L Microcomputer central signal alarm device

1、 Overview

The CAKJ-XHB series integrated microcomputer central signal alarm device is a centrally managed microcomputer signal alarm system designed specifically for power plants and substations. It has the characteristics of strong anti-interference ability, easy operation, easy installation and use, and small maintenance. This product is widely used in industries such as power, petroleum, chemical, metallurgy, and coal, and is an intelligent product for power and industrial automation monitoring and signal alarm.

2、 Functional characteristics

1. The device panel has digital display, setting buttons, and power on self-test.
2. It has the functions of testing (testing the lamp), confirming (accepting), silencing, resetting, and recalling. And it comes with built-in function buttons.
3. Equipped with manned and unmanned switching functions
4. It has manual and automatic confirmation functions, and the automatic confirmation time (0-200s) can be set.
5. Signal alarm types can be distinguished: accident signal S, warning signal Y, and position signal P can be set to distinguish.
6. Color of the light signboard: You can choose from white hair red, white hair white, white hair yellow, and white hair green. Depending on the alarm type of the signal, color differentiation is more eye-catching and intuitive.
7. Input signal types can be set: switch type contact (h), switch type holding contact (E), and pulse type holding contact (C). (Note)
8. Input signal normally open and normally closed selection: For each signal, a normally open to normally closed alarm can be set (default), and a normally closed to normally open alarm can be set.
9. Signal delay alarm: 0-9999ms delay alarm time can be set .
10. The device comes with a built-in buzzer, which emits a long beep for accidents and a short beep for warning signals. The position signal does not sound.
11. The device is equipped with accident and warning signal alarm output contacts, which can activate electric horns and bells to enhance the sound alarm effect.
12. Equipped with accident and warning remote signal output contacts, connected to other devices or used as accident stop signals.
13. Equipped with device power disappearance contact output.
14. Equipped with digital communication output, RS485 serial communication interface, and MODBUS communication protocol.

◆Note: Explanation of input signal status and alarm procedures

When“h” is selected as the input signal state (default), the workflow is as follows:

Line	Run	Button	Alarm status	Light plate	Sound status	Remark
1	Normal	-	Normal	Off	Silent	
2A	Abnormal	-	Alarm	Flash	Sound	Alarm
2B	Abnormal	Silence	Alarm	Flash	Silent	Alarm hold
3A	Abnormal	Confirm	Confirmed	Bright	Silent	Alarm hold
3B	Normal		-	To line 4		Instant alarm
4	Normal	-	Normal	Off	Silent	Automatic reset

When the state of the input signal is "C" or "E", the work flow is as follows:

Line	Run	Button	Alarm status	Light plate	Sound status	Remark
1	Normal	-	Normal	Off	Silent	
2A	Abnormal	-	Alarm	Flash	Sound	Alarm
2B	Abnormal	Silence	Alarm	Flash	Silent	Alarm hold
3A	Abnormal/Normal	Confirm	Confirmed	Bright	Silent	Alarm hold
3B	Normal to abnormal	-	Alarm	To line 2A		Restart alarm
4A	Abnormal	Reset	-	To line 3A		Alarm hold
4B	Normal		Normal	Off	Silent	Manual reset

Note: The signal is normal if the signal is not alarmed, and the signal abnormal is if it is alarmed

3、 Model specifications

model	alarm circuits	Series code	Signal type	elaborate on
CAKJ-XHB				Chang an Technology Integrated Signal Alarm Device
	-16			16 circuit alarm signals (16 alarm light signs), window 53x28mm
	-18			18 circuit alarm signals (18alarm light signs), window 53x28mm
	-24			24 circuit alarm signals (24 alarm light signs), window 53x28mm
	-32			32 circuit alarm signals (32 alarm light signs), window 53x28mm
	-36			36 circuit alarm signals (36 alarm light signs), window 53x28mm
	-48			48 circuit alarm signals (48 alarm light signs), window 53x28mm
	-64			64 circuit alarm signals (64 alarm light signs), window 53x28mm
	-72			72 circuit alarm signals (72 alarm light signs), window 53x28mm
	-96			96 circuit alarm signals (96 alarm light signs), window 53x28mm
	-128			128 circuit alarm signals (128 alarm light signs), window 53x28mm
	-192			192 circuit alarm signals (192 alarm light signs), window 53x28mm
		L		Digital window settings, L series size
			empty	The alarm signal is a passive empty contact signal input
			-A	The alarm signal is an active voltage signal input (DC220V, DC110V, DC125V, etc., specified when ordering)

Note: When using AC power supply, select active contact input and only use holding signal, which needs to be manually reset. Otherwise, indicate the signal DC voltage

4、 General technical requirements

1. Working power supply: AC, DC80-265V wide voltage, or user-defined.
2. Signal capacity: 16,18,24,32,36,48,64,96,128,192 circuits.
3. Input signal method: normally open passive dry contact or active DC voltage signal.
4. Light signboard: The luminous window size is 53x28. Color: White, red, green, and yellow (amber) are optional, and different colors are displayed when an alarm occurs.
5. Alarm output: Flashing light signs, buzzer or sound system.
6. Alarm sound: The buzzer beeps for 60dB; Expanding audio options include our company's CAKJ-DL bell, CAKJ-DD whistle, and CA-XXXS-YX2 electronic audio system.
7. Contact output: 5 relay contact outputs, corresponding to power loss, pre alarm, accident alarm, pre alarm remote signaling (follow-up opening), and accident remote signaling (follow-up opening).
8. Contact capacity: AC250V, 3A pure resistive load, DC220V, 0.125A inductive load.
9. Function setting: Touch the button to set, 5-digit LED display
10. Power consumption: The total power consumption for 16-96 channels is not more than 50W, and for 128-192 channels, it is not more than 100W.
11. Communication interface: Standard RS485 serial communication interface, MODBUS communication protocol
12. Insulation resistance: not less than 100M Ω between input output power supply housing
13. Power frequency withstand voltage: Can withstand a test of 2kV, 1min, 5mA, 50/60Hz between input output power supply and housing, without flashover or breakdown.
14. Anti interference capability: capable of withstanding high-frequency interference tests with attenuation oscillations of 1MHz and 100kHz. The first half wave voltage amplitude has a common mode of 2.5kV and a differential mode of 1.0kV, and the product should not exhibit any misoperation or refusal to operate.
15. Environmental conditions: Environmental temperature -10 °C~60 °C; Environmental humidity not exceeding 90%
16. Weight: 5kg

5、 Device alarm and inspection

1. Power on self-test, the device is powered on and the back power switch is turned on. The numerical settings window on the device panel displays [0.0.0.0.0], [1.1.1.1.1]... [7.7.7.7], [8.8.8.8.8], and the light plate is all on. [9.9.9.9] The light plate is all on until it scrolls to display [C-nL] (as a power indicator), and the light plate is off, completing the power on self-test.
2. Press the "Test" button, all light signs will flash, the buzzer will sound, and the output sound contact will act. Release the test button and return to monitoring status.
When a signal alarm occurs, the corresponding light sign flashes, the buzzer sounds, the output sound contact acts, the electric bell and whistle sound, and the remote signaling contact acts. The digital display window displays the corresponding number of circuits.
4. Press the "mute" button, the light sign will remain flashing, the buzzer will remain silent, the output sound contact will return, and the bell and whistle will remain silent.
5. Press the "Confirm" button (or automatically confirm within 0-200s), the light sign will change from flashing to flat light, the buzzer will be silent, the output sound contact will return, and the bell and whistle will be silent.
When the signal is reset, the signal input from the switch type contact will turn off the light plate and the remote signaling contact will return. The signal light sign of the holding type contact input will remain in alarm. After manual reset (pressing the "reset" button), the light sign will go out and the remote signal contact will return.
7. Press and hold the "recall" button, and the alarm signals will flash one by one on the light plate according to their alarm sequence, following the principle of last in, first out. At the same time, the LED will synchronously display the alarm circuit, and up to 200 signals can be recalled. Alarm priority will be given during recall.
8. Switching between manned and unmanned mode, connect self-locking switches or buttons at N6 and C4 ends, and switch to unmanned mode when N6 and C4 are connected. When there is no one on duty, the digital display shows "-----", the signal alarm light sign, sound system, etc. do not work, and the communication interface and remote signal contact output are in normal use.

6、 Device settings

Press the "SET" setting key, shift the "←" key, add 1 to the "↑" key, and enter the password (8080) to enter the setting state. Press "SET" according to the menu prompts to flip through various function settings. (Version number: v3.2.1)

Set symbol	Set Content	Operation buttons	set range	Default value (description)
C 0	Enter password	"←" "↑"	password	8080
n. n	Alarm main circuit	"SET"	Route 16-192	64 (if it is 64 channels) This is the factory setting
E. 30	Set automatic confirmation time	"←" "↑"	0-200s	30s (not automatically confirmed when set to "0")
d. 20	Set signal delay alarm time	"←" "↑"	0-9999ms	20, 20ms,
Y-A	Alarm sound settings	Select "↑"	A, F, d, n	A (A sound system fully open, F only buzzer, D only external electronic sound system, n sound system fully closed)
S. 1	Device comm. address	"←" "↑"	0-255	1 (The mailing address is unique)
b. 9600	Baud rate	Select "↑"	9600/4800	9600
J. 0	Memory signal clearing	"←" "↑"	Clear password	1001 (Correct password clearing record)
L01-y	Set 01 signal alarm type	Select "↑",	y, S, P	y (By default, all signals in the device are "y" warning signals. According to each signal type, press "↑" to select "S" accident signal, press "↑" to select "P" position signal, select completed, press "←" to turn the page and set signal types one by one.)
L02 y	Set 02 signal alarm type	Flip the page and set the signal types one by one		
--- ----	----			
Ln y	Set n signal alarm types			
E01-h	Set 01 signal input status	Select "↑",	h, C, E	h (default switch type contact for device h), press "↑" to select "C" pulse type holding contact, press "↑" to select "E" switch type holding contact, select completed, press "←" to turn pages and set signal status one by one
E02-h	Set 02 signal input status	Flip the page and set the input status one by one		
--- ----	----			
En h	Set n signal input status			
F01-o	Set 01 signal on/off alarm	Select "↑",	o, C	o (The device defaults to a normally open contact closure alarm), press "↑" to select "C" for a normally closed contact disconnection alarm, complete the selection, press "←" to turn the page, and set signal on/off alarms one by one.)
F02-o	Set 02 signal on/off alarm	Flip the page and set the input status one by one		
--- ----	----			
Fn o	Set n signal on/off alarm			

Press the "SET" button directly to save or exit the settings after completion or without setting, and restore the normal alarm state.

◆Signal unified setting table; Press "SET" to enter the settings, press "←" to shift, press "↑" to add 1, enter the code, press "SET" to complete the settings and return

Enter code	Set 1-n signal alarm types	Enter code	Set 1-n signal input status
C1101	Unified setting as accident signal S	C1104	Unified setting as switch contact h
C1102	Unified setting as preview signal y	C1105	Unified setting as pulse contact C
C1103	Unified setting as position signal P	C1106	Uniformly set to maintain contact E

Note: This setting is for the convenience of users to set all signals to one type or state on site, and should not be operated easily.

7、 Product specifications, detailed description

System and Line Diagram (Note: It is best for users to provide the name of each alarm signal and the color of the alarm time plate when placing an order, so that it can be set before leaving the factory)

◆Basic control operation circuit

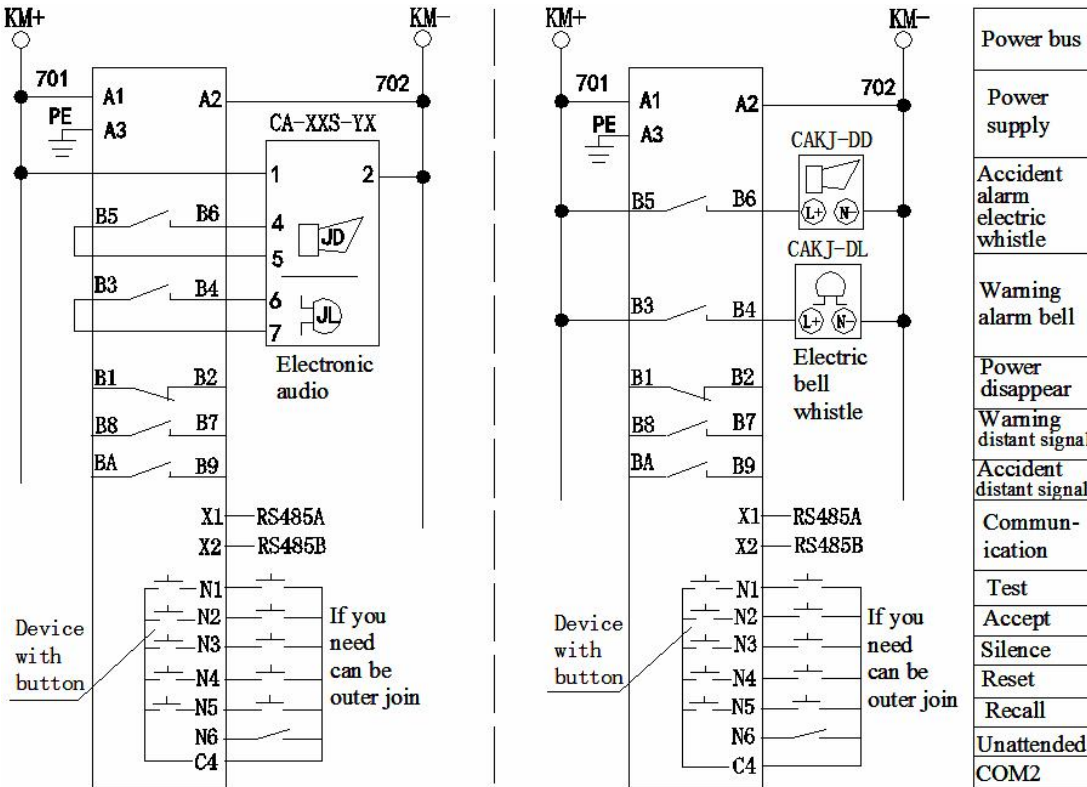

◆Signal input circuit wiring diagram

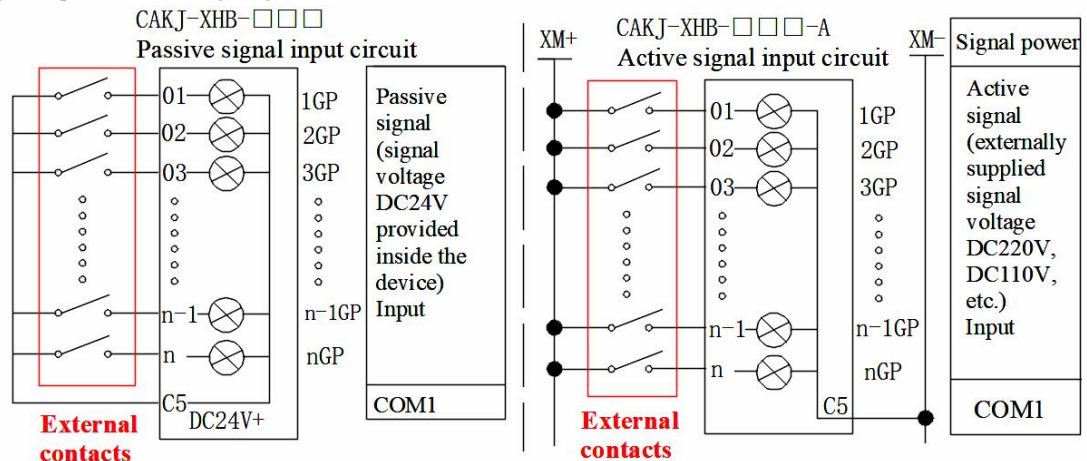

◆Schematic diagram of passive dry contact and active voltage signal input

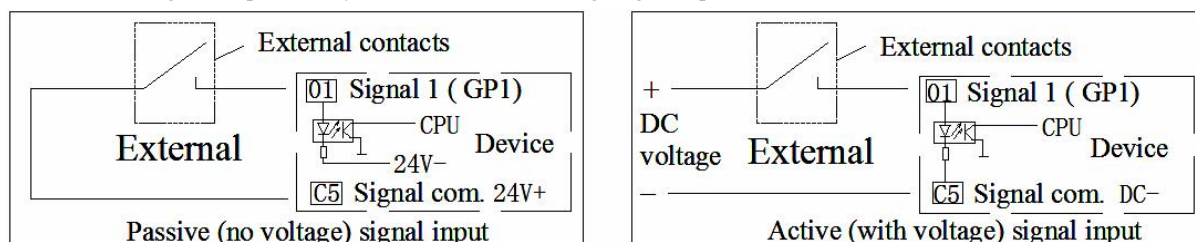

◆ Ordering selection

Passive (no voltage) signal input and active (with voltage) signal input methods, due to the need for hardware circuit changes, the correct model should be selected when ordering:

CAKJ-XHB - □ L is a passive signal input. When placing an order, please specify whether the power supply voltage is AC or DC voltage.

CAKJ-XHB - □ L-A is an active signal input. When ordering, it is necessary to specify the DC voltage of the signal power supply and the AC or DC voltage of the power supply.

Note: Please provide the name and color of each alarm signal when placing an order, so that it can be configured properly at the factory.

★ Transparent paper for printing alarm names on light signs
Or the schematic diagram for replacing the luminous board

The LED light emitting board of the light license plate can be specified in colors, red, yellow (amber), green, and white.
When there is no alarm, it is white, and when there is an alarm, the color is distinguished.

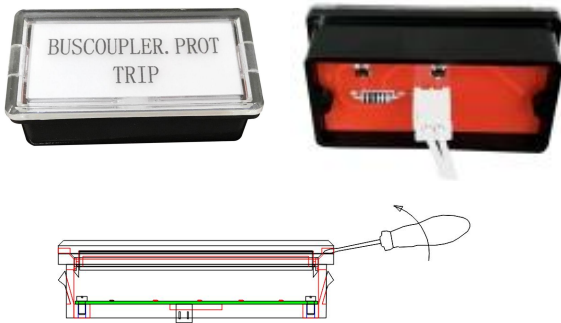

Method of opening the transparent cover

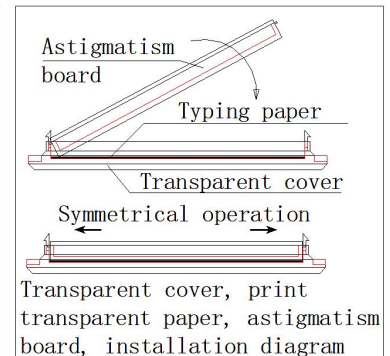
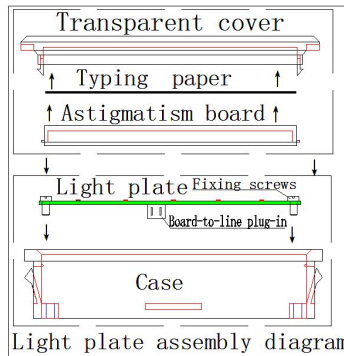

◆ Legend of central signal alarm device

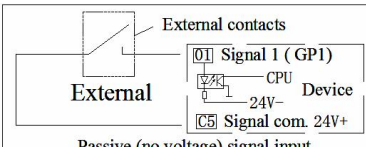
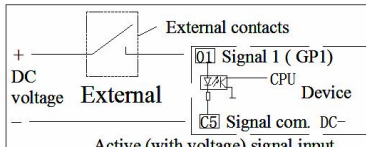

Meaning of wiring terminals

Basic functional terminals		Alarm signal input terminal													explain
Terminal number	meaning	Terminal number													
A1	Power supply L/+	01	17	33	49	65	81	97	113	129	145	161	177		Passive dry contact signal input terminal or active voltage signal DC+terminal
A2	Power supply N/-	02	18	34	50	66	82	98	114	130	146	162	178		
A3	Power supply PE	03	19	35	51	67	83	99	115	131	147	163	179		
B1	Power failure normally closed	04	20	36	52	68	84	100	116	132	148	164	180		
B2	Power failure normally closed	05	21	37	53	69	85	101	117	133	149	165	181		
B3	Announcement audio contact point	06	22	38	54	70	86	102	118	134	150	166	182		
B4	Announcement audio contact point	07	23	39	55	71	87	103	119	135	151	167	183		
B5	Accident audio contact	08	24	40	56	72	88	104	120	136	152	168	184		
B6	Accident audio contact	09	25	41	57	73	89	105	121	137	153	169	185		
B7	Advance notice of main remote signaling contact point	10	26	42	58	74	90	106	122	138	154	170	186		
B8	Advance notice of main remote signaling contact point	11	27	43	59	75	91	107	123	139	155	171	187		
B9	Accident main remote signaling contact	12	28	44	60	76	92	108	124	140	156	172	188		
BA	Accidents always require a reliable contact point	13	29	45	61	77	93	109	125	141	157	173	189		
NC	Backup (communication)	14	30	46	62	78	94	110	126	142	158	174	190		
NC	Backup (communication)	15	31	47	63	79	95	111	127	143	159	175	191		
X1	RS485A	16	32	48	64	80	96	112	128	144	160	176	192		
X2	RS485B	C5	C5	C5	C5	C5	C5	C5	C5	C5	C5	C5	C5		Signal common terminal C5
XD	Communication location	C5 is the input terminal (common terminal) for passive dry contact signals, or the DC terminal for active voltage signals.													
External button (can be external if needed)		All C5 terminals of the device are connected together, with one C5 leading out below 64 channels and one C5 leading out every 64 channels exceeding 64 channels.													
N1	test	Passive dry contact signal active voltage signal  													
N2	confirm														
N3	Silencing														
N4	reset														
N5	Recalling														
N6	Unattended														
C4	Public end														

8. Device dimensions and opening diagram (depth dimension 92mm)

◆ 16-circuit central signal alarm device

1. Model and specifications

Product Model	Alarm Circuit	Input Signal Type	Signal Voltage	Power supply
CAKJ-XHB-16L	16 Circuits	Passive dry contact signal input	not have	AC or DC
CAKJ-XHB-16L-A	16 Circuits	Active voltage signal input	DC110V,DC220V etc	80-265V

2. 16L appearance graphics

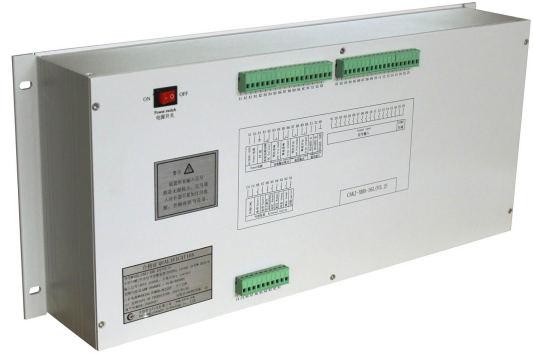
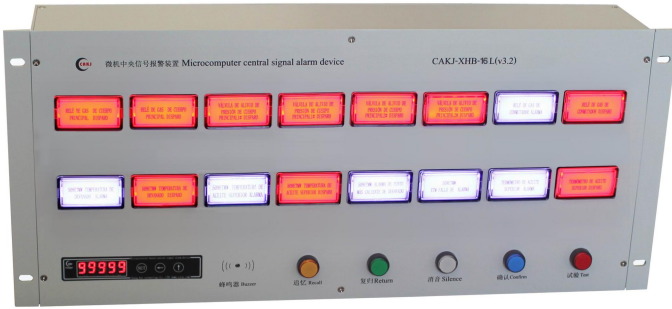

3. 16L appearance and installation hole size

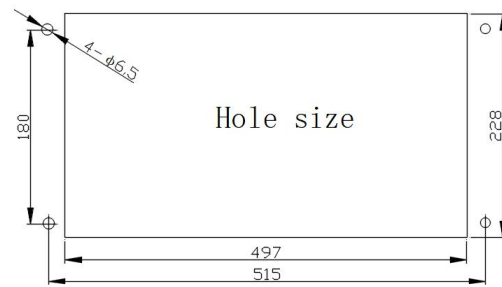
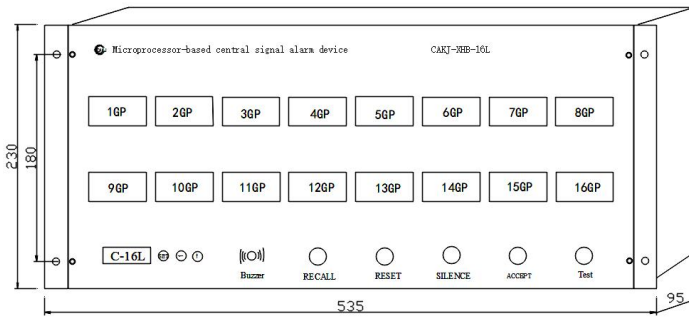

4. 16L wiring and location diagram

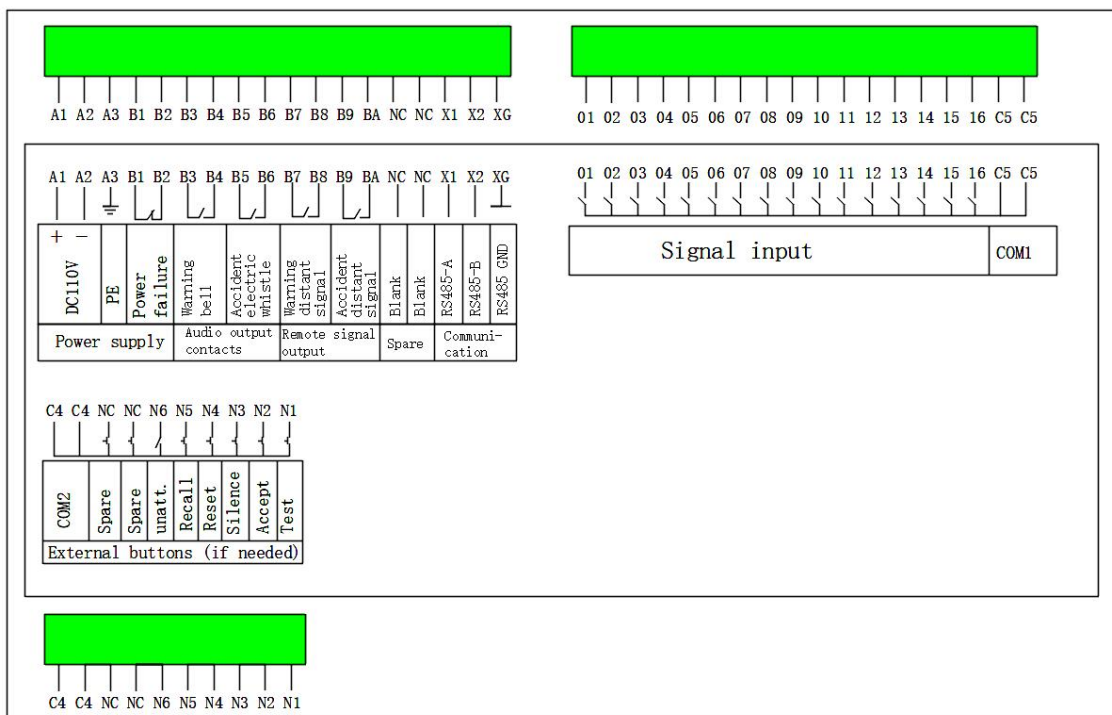

◆ 18-circuit central signal alarm device

1. Model and specifications

Product Model	Alarm Circuit	Input Signal Type	Signal Voltage	Power supply
CAKJ-XHB-18L	18 Circuits	Passive dry contact signal input	not have	AC or DC 80-265V
CAKJ-XHB-18L-A	18 Circuits	Active voltage signal input	DC110V,DC220V etc	

2. 18L appearance graphics

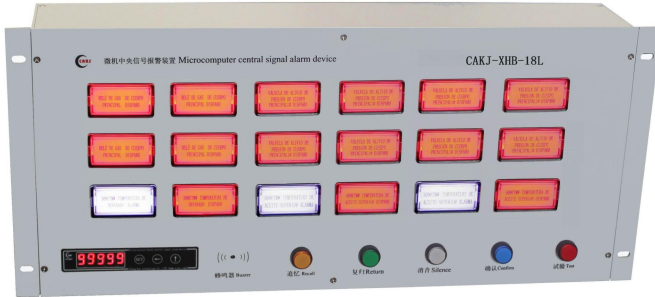

3. 18L appearance and installation hole size

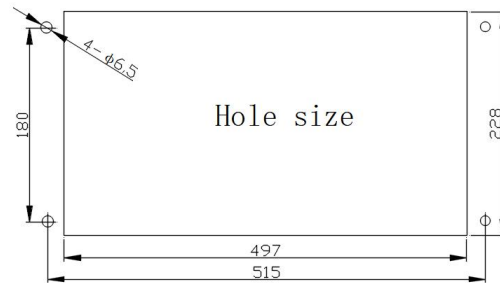
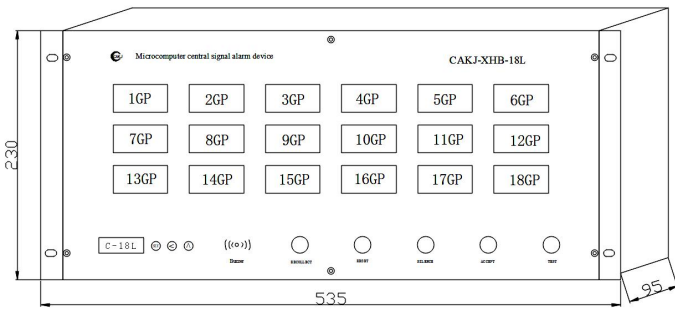

4. 18L wiring and location diagram

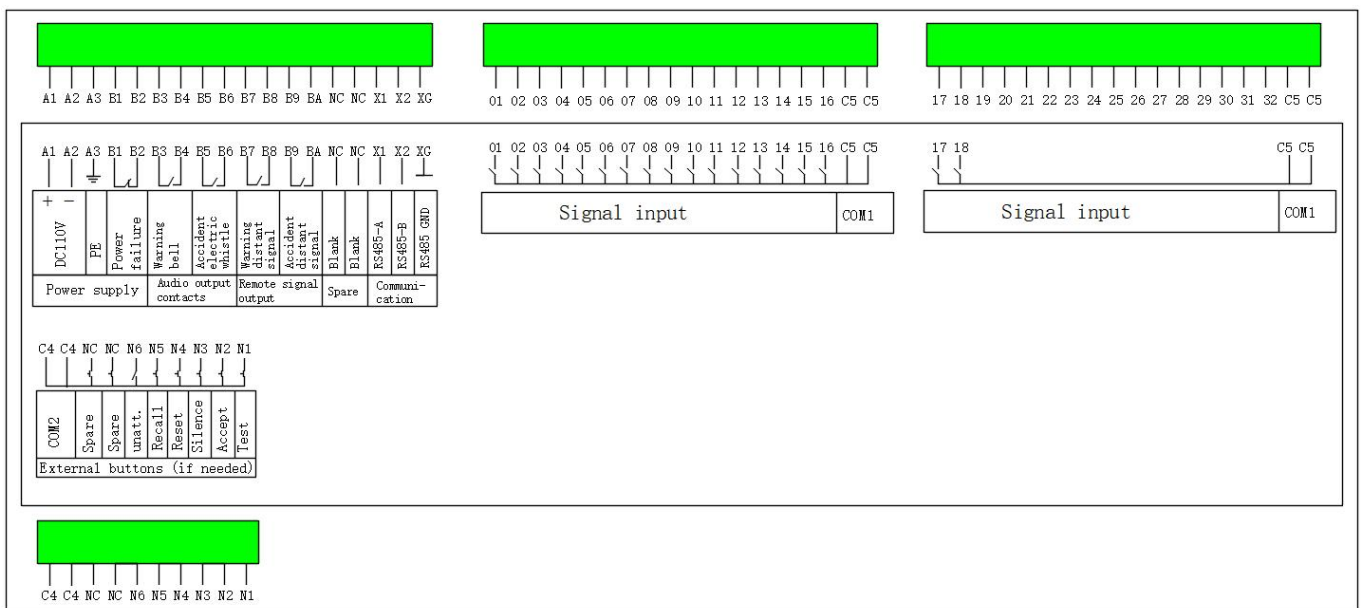

◆ 24-circuit central signal alarm device

1. Model and specifications

Product Model	Alarm Circuit	Input Signal Type	Signal Voltage	Power supply
CAKJ-XHB-24L	24 Circuits	Passive dry contact signal input	not have	AC or DC
CAKJ-XHB-24L-A	24 Circuits	Active voltage signal input	DC110V,DC220V etc	80-265V

2. 24L appearance graphics

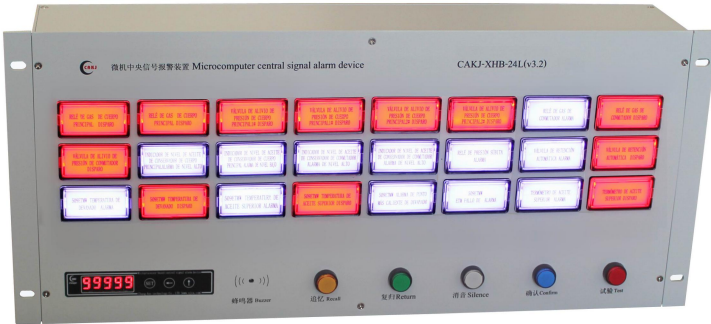

3. 24L appearance and installation hole size

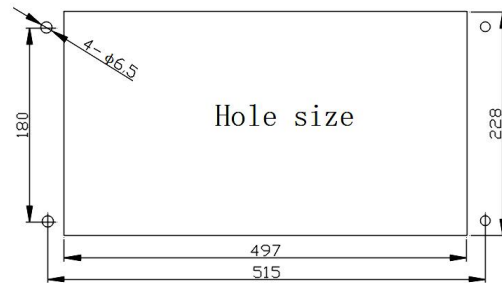
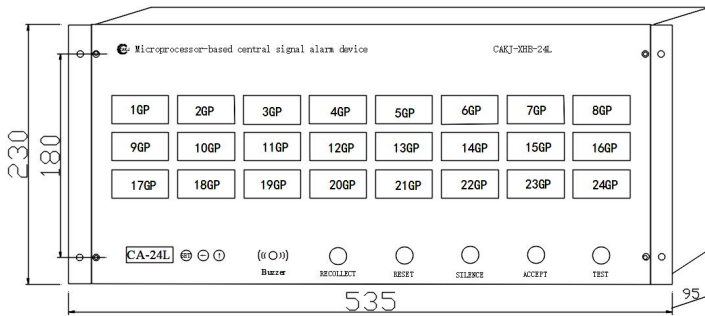

4. 24L wiring and location diagram

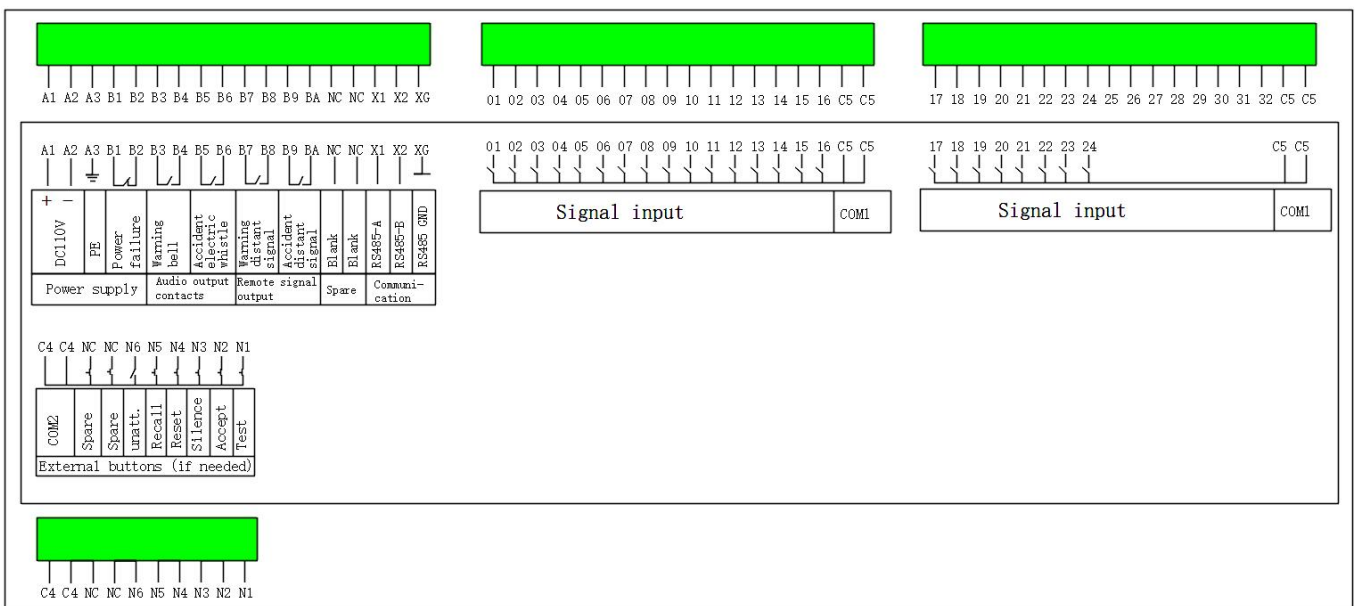

◆32-circuit central signal alarm device

1. Model and specifications

Product Model	Alarm Circuit	Input Signal Type	Signal Voltage	Power supply
CAKJ-XHB-32L	32 Circuits	Passive dry contact signal input	not have	AC or DC 80-265V
CAKJ-XHB-32L-A	32 Circuits	Active voltage signal input	DC110V,DC220V etc	

2. 32L appearance graphics



3. 32L appearance and installation hole size

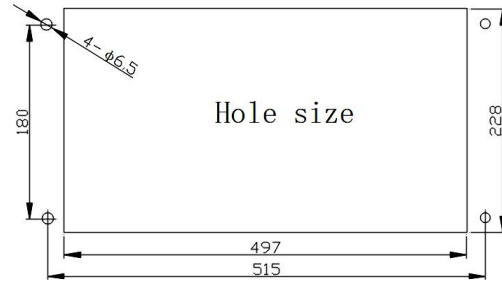
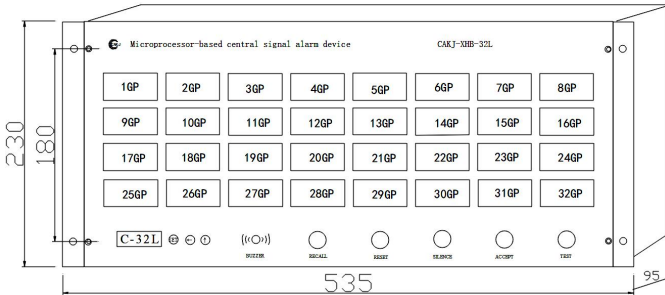

4. 32L wiring and location diagram

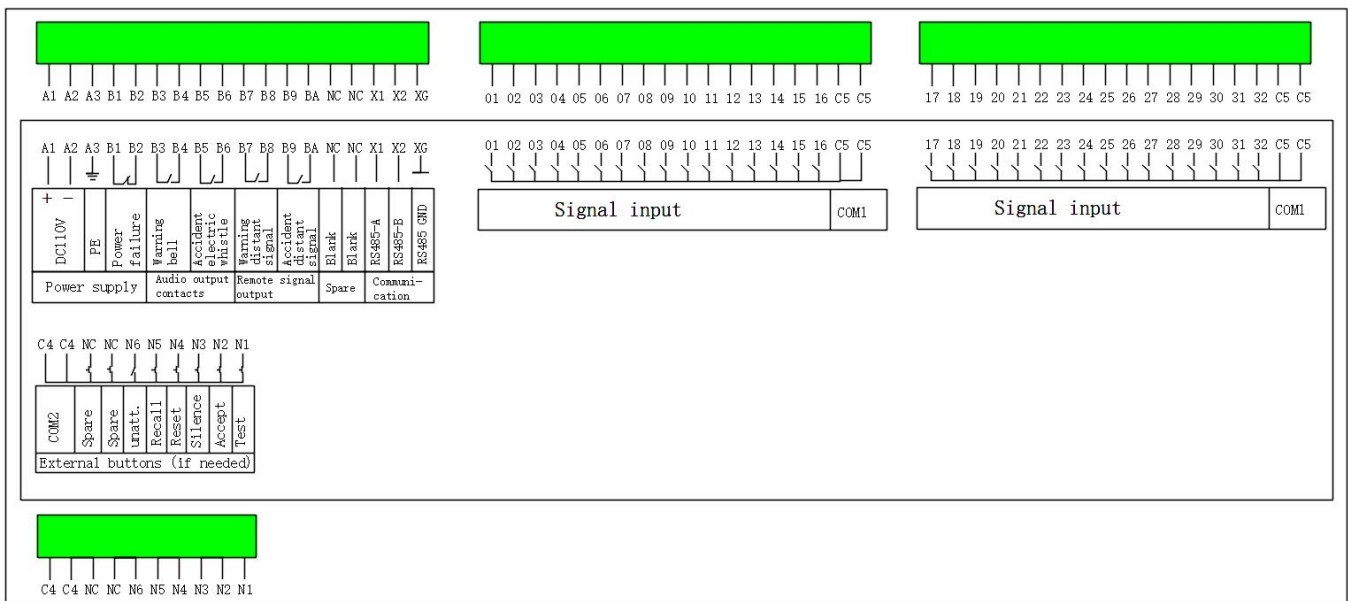

◆36-circuit central signal alarm device

1. Model and specifications

Product Model	Alarm Circuit	Input Signal Type	Signal Voltage	Power supply
CAKJ-XHB-36L	36 Circuits	Passive dry contact signal input	not have	AC or DC
CAKJ-XHB-36L-A	36 Circuits	Active voltage signal input	DC110V,DC220V etc	80-265V

2. 36L appearance graphics

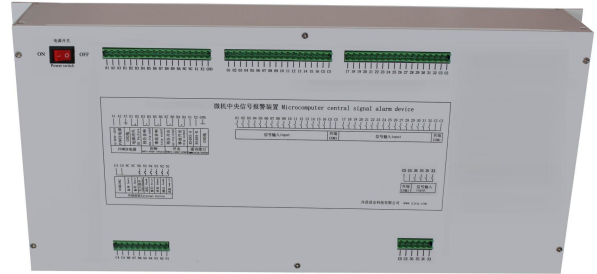
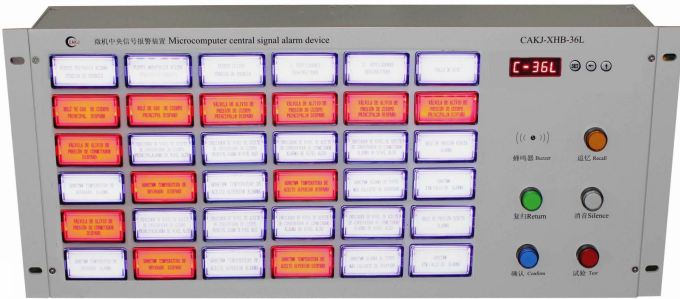

3. 36L appearance and installation hole size

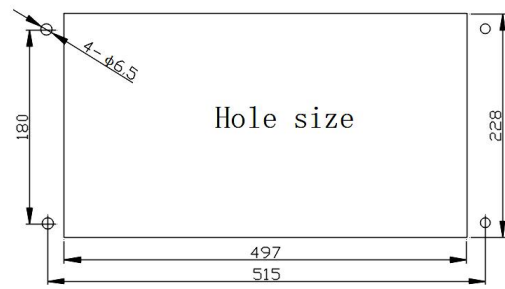
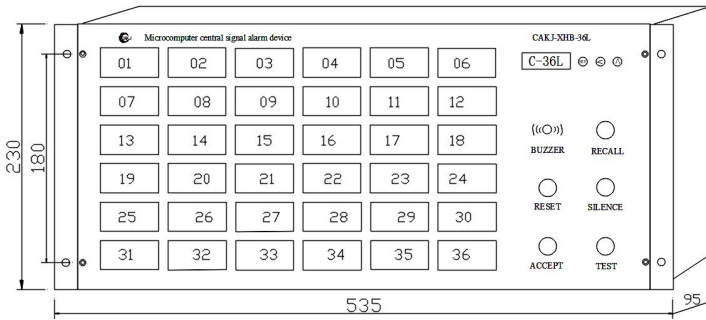

4. 36L wiring and location diagram

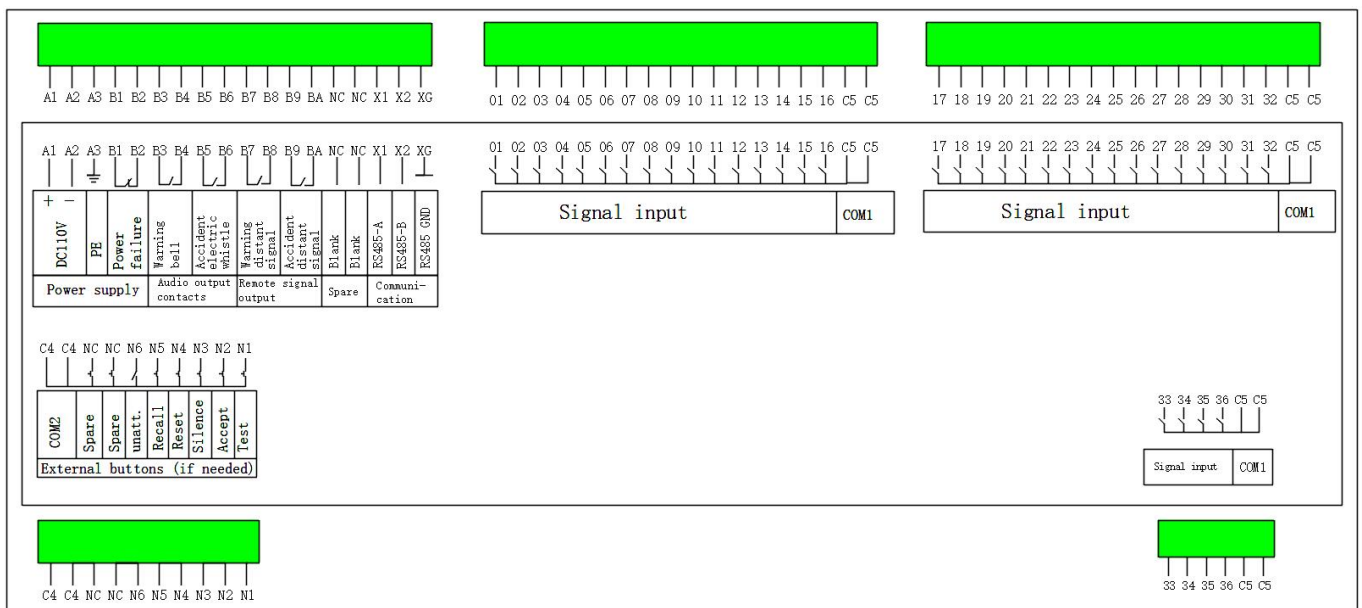

◆48-circuit central signal alarm device

1. Model and specifications

Product Model	Alarm Circuit	Input Signal Type	Signal Voltage	Power supply
CAKJ-XHB-48L	48 Circuits	Passive dry contact signal input	not have	AC or DC 80-265V
CAKJ-XHB-48L-A	48 Circuits	Active voltage signal input	DC110V,DC220V etc	

2. 48L appearance graphics



3. 48L appearance and installation hole size

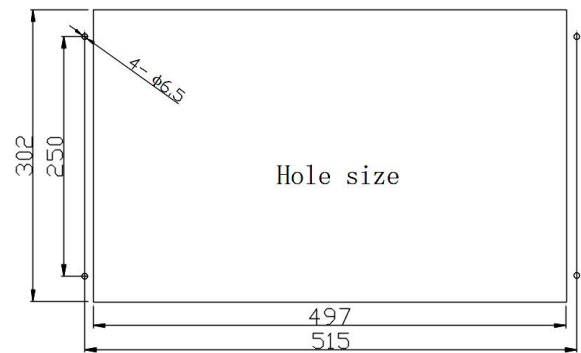
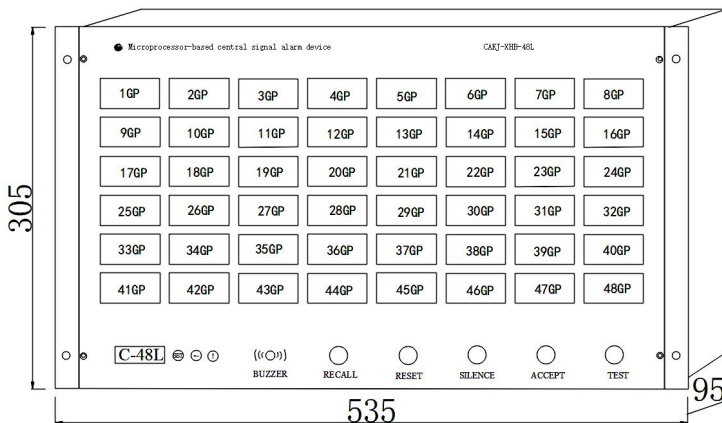

4. 48L wiring and location diagram

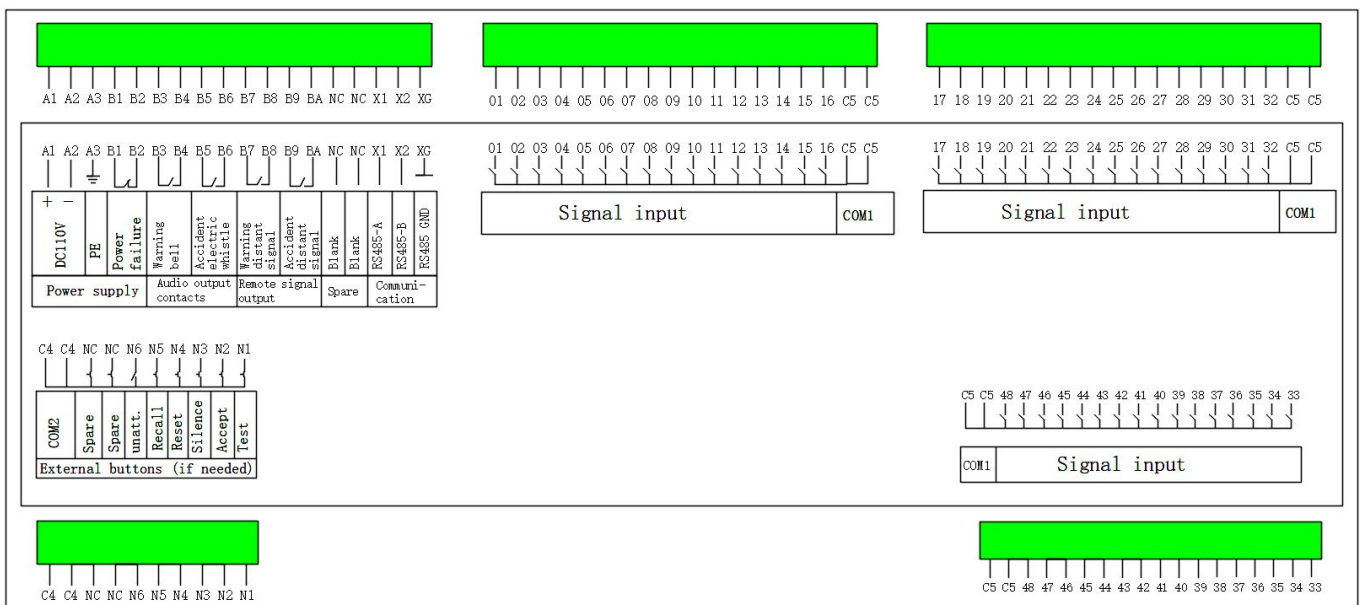

◆ 64-circuit central signal alarm device

1. Model and specifications

Product Model	Alarm Circuit	Input Signal Type	Signal Voltage	Power supply
CAKJ-XHB-64L	64 Circuits	Passive dry contact signal input	not have	AC or DC
CAKJ-XHB-64L-A	64 Circuits	Active voltage signal input	DC110V,DC220V etc	80-265V

2. 64L appearance graphics

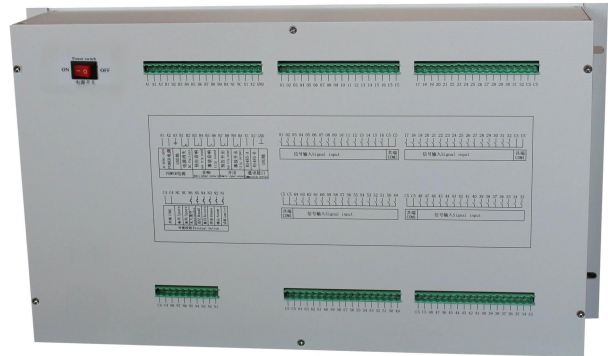
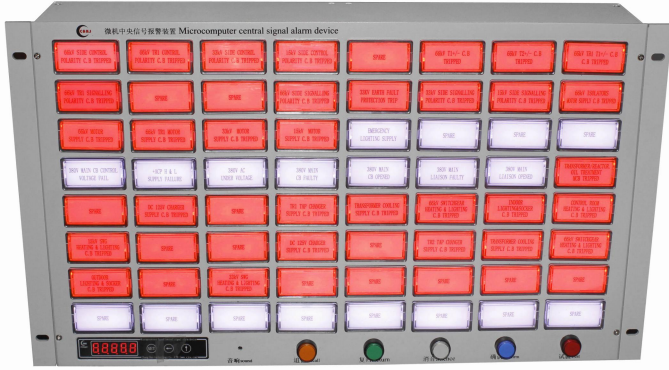

3. 64L appearance and installation hole size

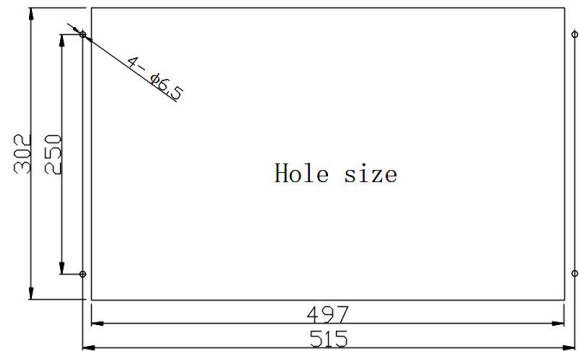
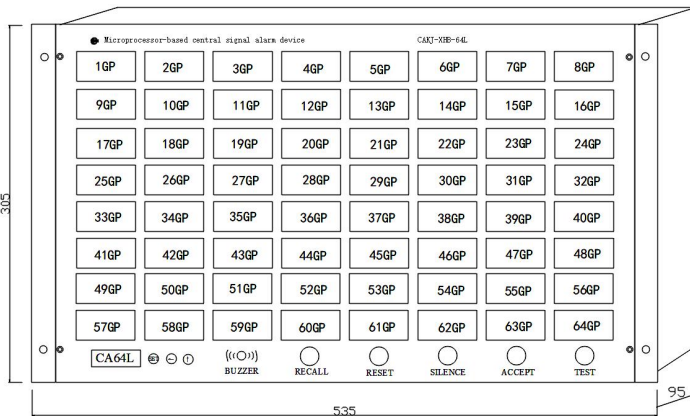

4. 64L wiring and location diagram

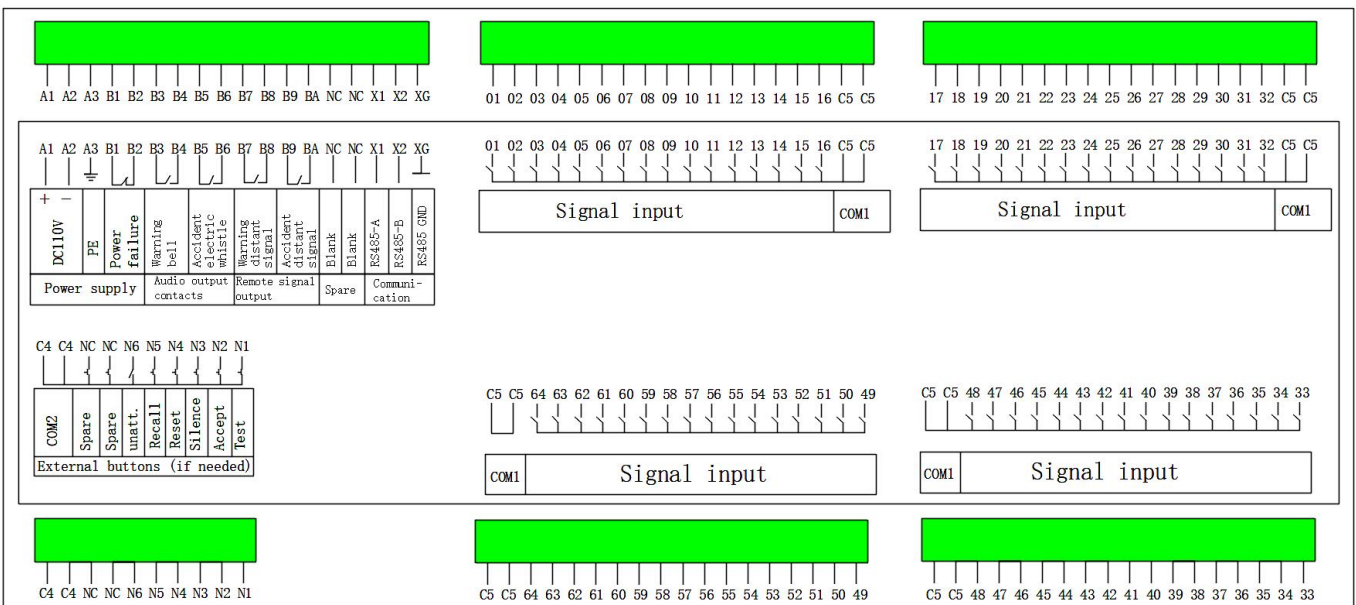

◆ 72-circuit central signal alarm device

1. Model and specifications

Product Model	Alarm Circuit	Input Signal Type	Signal Voltage	Power supply
CAKJ-XHB-72L	72 Circuits	Passive dry contact signal input	not have	AC or DC
CAKJ-XHB-72L-A	72 Circuits	Active voltage signal input	DC110V,DC220V etc	80-265V

2. 72L appearance graphics



3. 72L appearance and installation hole size

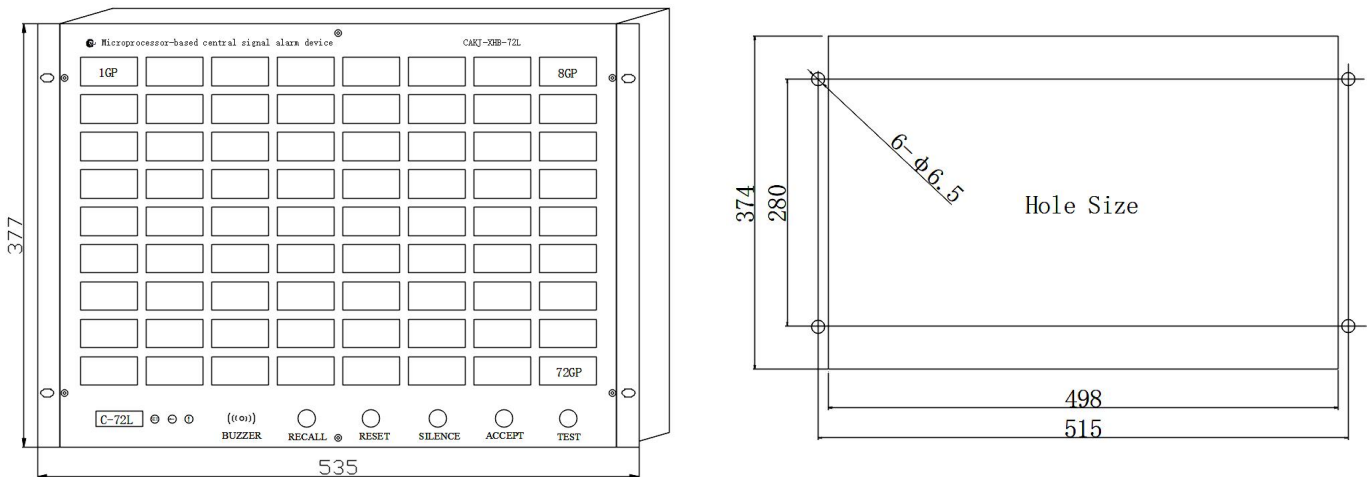

4. 72L wiring and location diagram

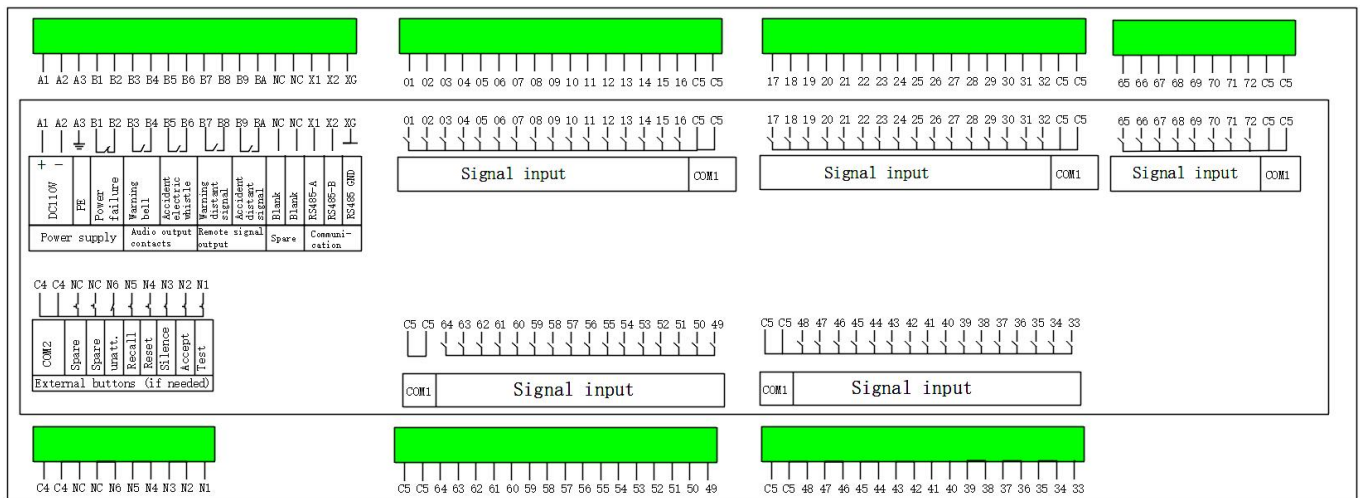

◆ 96-circuit central signal alarm device

1. Model and specifications

Product Model	Alarm Circuit	Input Signal Type	Signal Voltage	Power supply
CAKJ-XHB-96L	96 Circuits	Passive dry contact signal input	not have	AC or DC
CAKJ-XHB-96L-A	96 Circuits	Active voltage signal input	DC110V,DC220V etc	80-265V

2. 96L appearance graphics

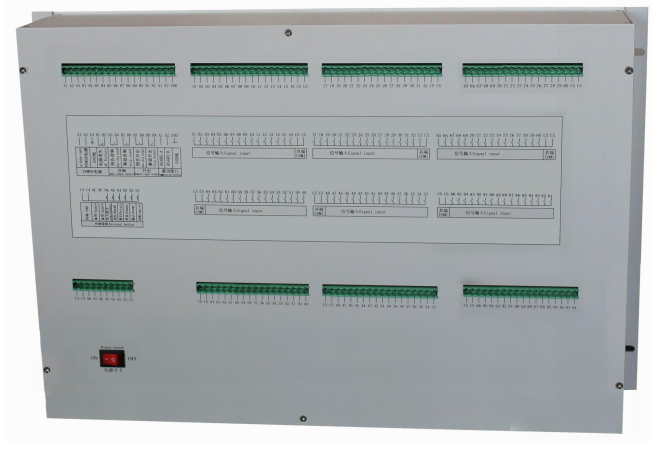
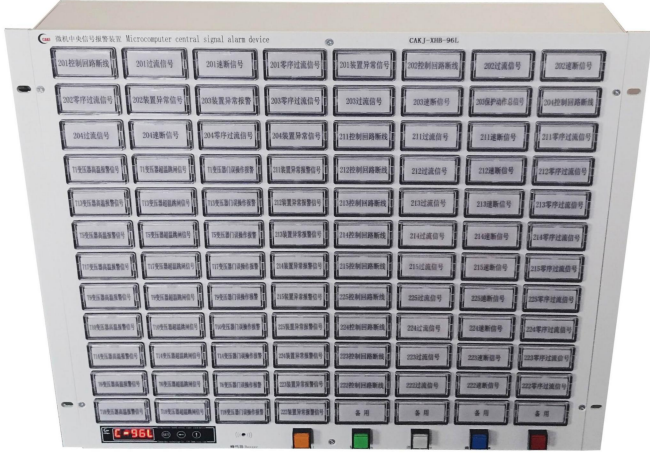

3. 96L appearance and installation hole size

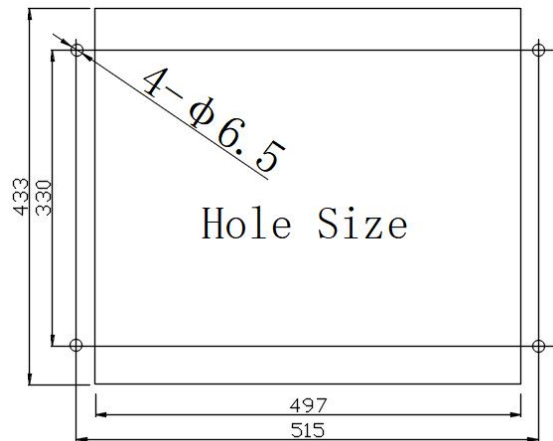
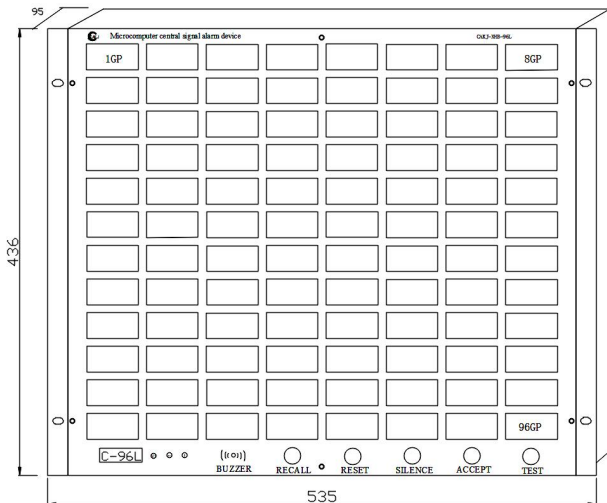

4. 96L wiring and location diagram

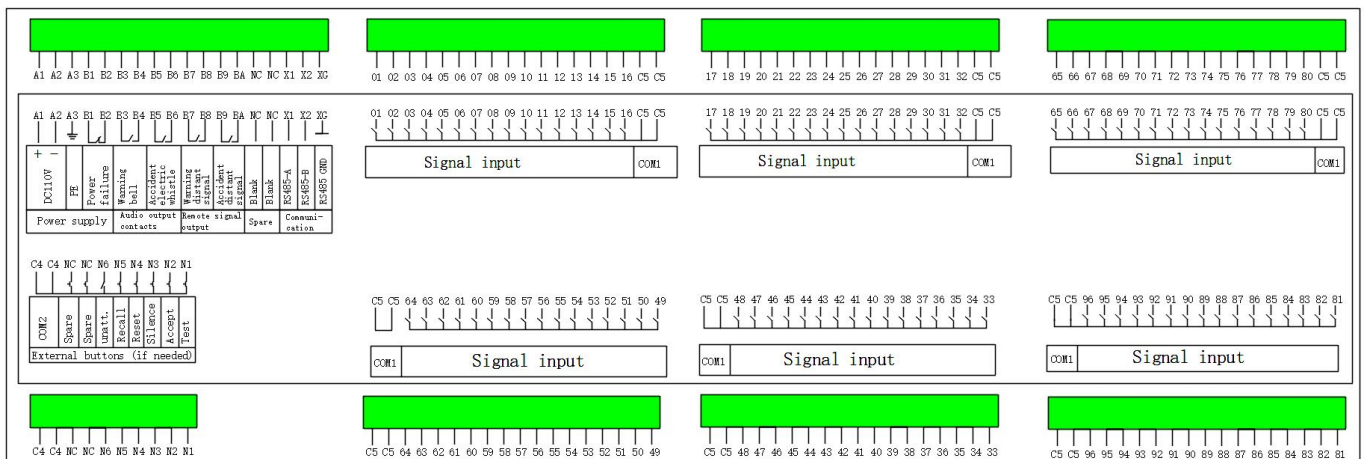

◆ 128-circuit central signal alarm device

1. Model and specifications

Product Model	Alarm Circuit	Input Signal Type	Signal Voltage	Power supply
CAKJ-XHB-128L	128 Circuits	Passive dry contact signal input	not have	AC or DC
CAKJ-XHB-128L-A	128 Circuits	Active voltage signal input	DC110V,DC220V etc	80-265V

2. 128L appearance graphics



3. 128L appearance and installation hole size

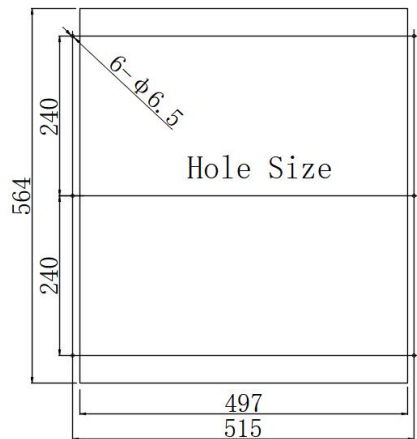
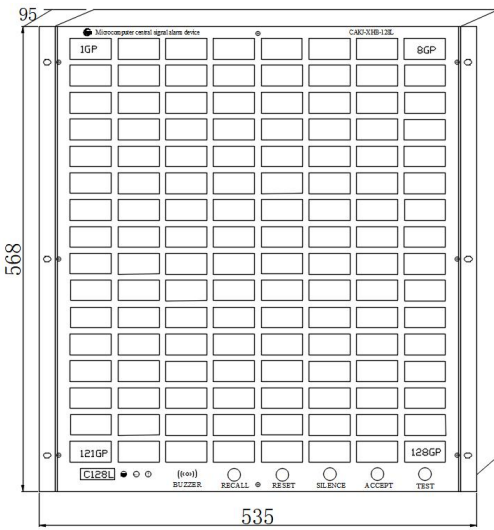

4. 128L wiring and location diagram

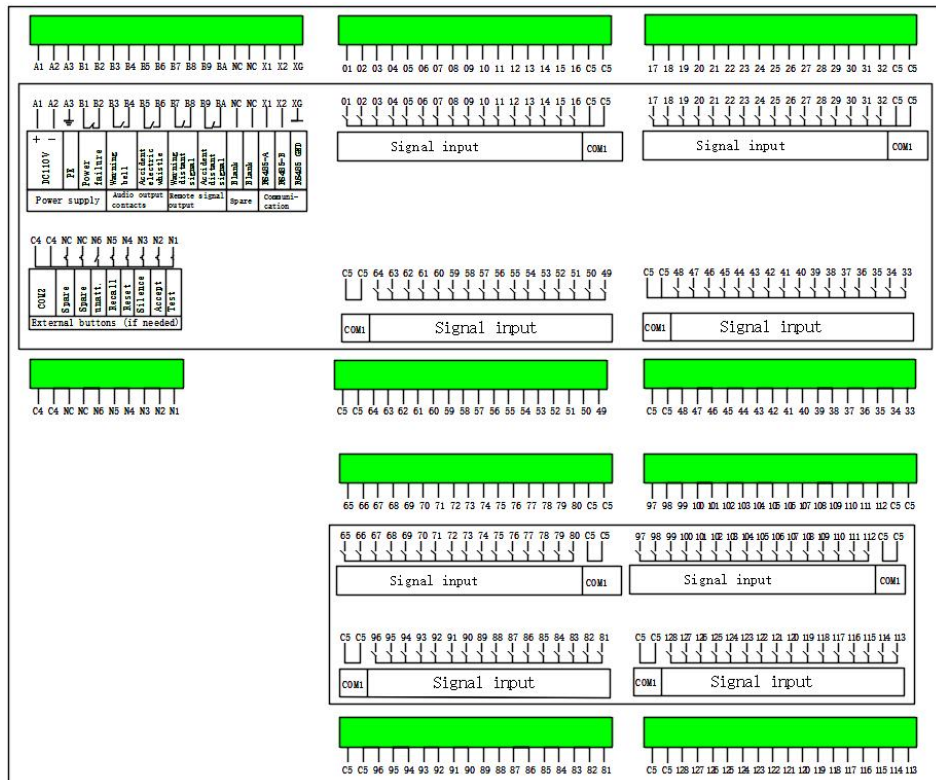

◆ 192-circuit central signal alarm device

1. Model and specifications

Product Model	Alarm Circuit	Input Signal Type	Signal Voltage	Power supply
CAKJ-XHB-192L	192 Circuits	Passive dry contact signal input	not have	AC or DC
CAKJ-XHB-192L-A	192 Circuits	Active voltage signal input	DC110V,DC220V etc	80-265V

2. 192L appearance graphics



3. 192L appearance and installation hole size

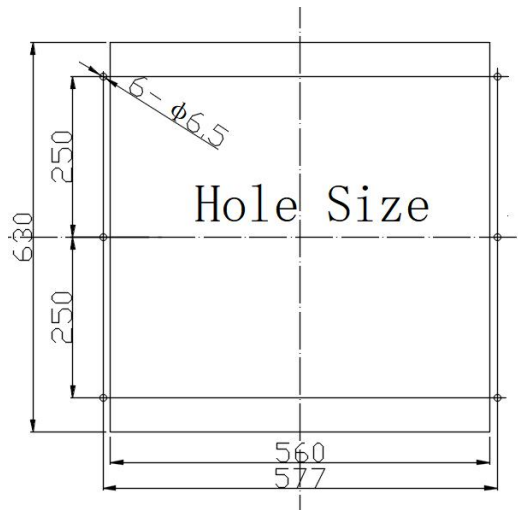
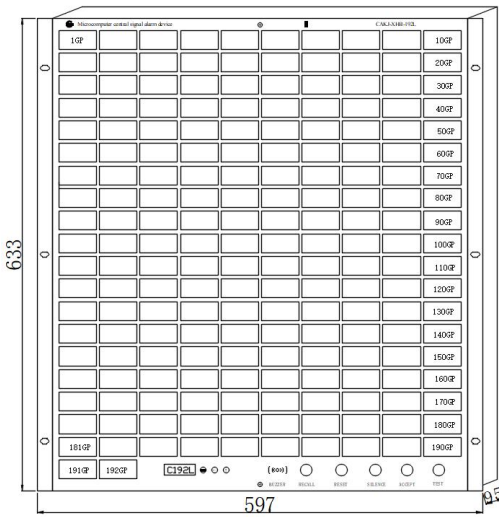

5. 192L wiring and location diagram

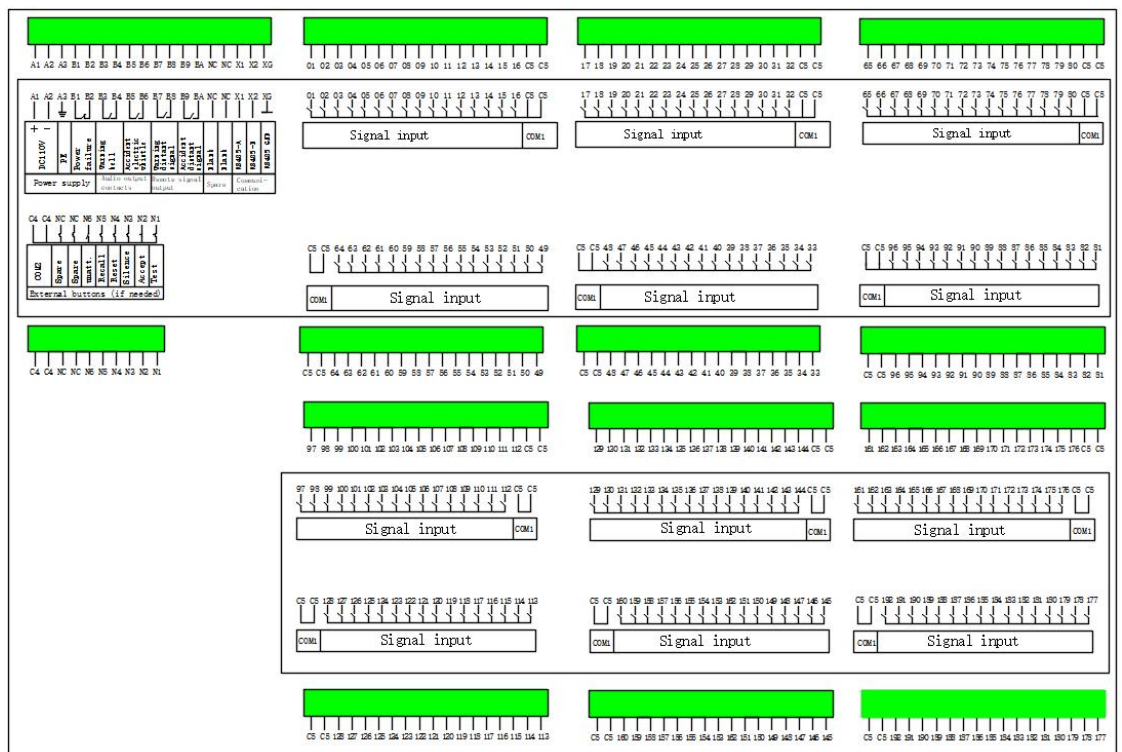

Electronic bell and whistle (optional)

1、 Overview

CAKJ-DL, DD electronic bell and whistle, is a low-power, non-interference, and high-volume electronic alarm device designed for central signal alarm in the power system. Using a microcontroller to simulate the sound spectrum of an electromagnetic bell and whistle, the similarity between its sound and that of an electromagnetic bell and whistle reaches 98%.

2、 Model specifications

CAKJ-DL Electronic Bell

CAKJ-DD Electronic Horn

3、 Technical parameters

Working power supply: AC, DC80-265V,
wide voltage AC/DC universal, DC24V specified when ordering

Power consumption: not more than 3VA

Sound volume: 120DB

Electric ringtone: beeping ringtone, uninterrupted sound

Electric flute sound: beep, uninterrupted sound

Working mode: Power on sounds, power off sounds silent

Dielectric performance

Isolation voltage: Input terminal to ground 3000V, 1 minute

Insulation resistance: > 100M Ω.

Anti interference capability: The product can withstand the electrical fast transient pulse group immunity test with a test level of 4 specified in Chapter 5 of GB/T 17626.4-2008

Applicable environment: Temperature -25~55 °C, humidity not exceeding 90% RH

Mean time between failures: not less than 50000h

4、 External dimensions and wiring

External dimensions: 80x110x100mm

Installation method: 35mm guide rail installation

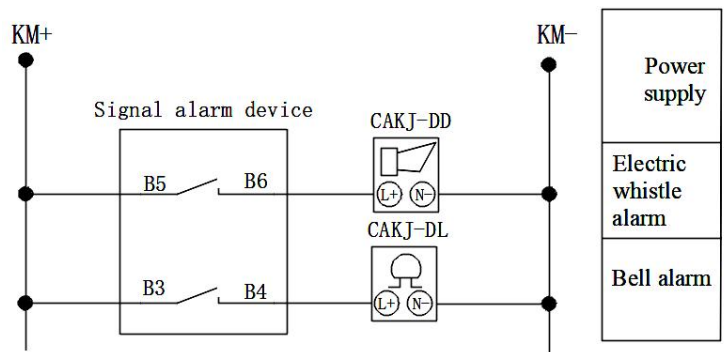
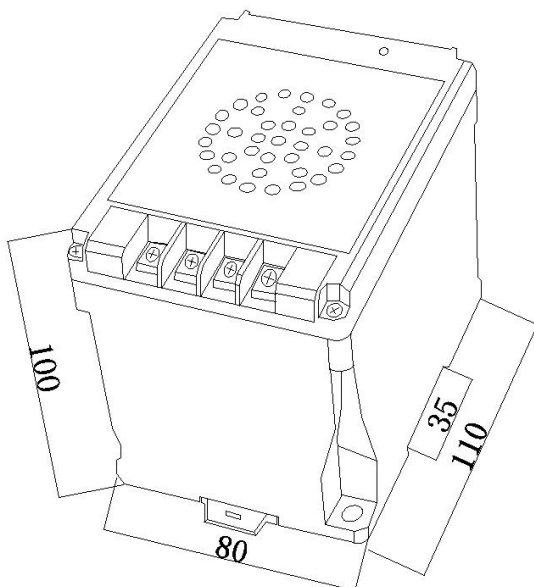

CAKJ-DDL72 Electronic Bell and Flute (Embedded) (Optional)

1、 Overview:

CAKJ-DDL72 Electronic Bell and Horn is a low-power, non-interference, and high-volume electronic alarm device designed for central signal alarm in power systems. Using a microcontroller to simulate the sound spectrum of an electromagnetic bell and whistle, the similarity between its sound and that of an electromagnetic bell and whistle reaches 98%.

2、 Technical parameters

Working power supply: AC, DC80-265V, wide voltage AC/DC universal, DC24V. When ordering, specify power consumption: not more than 3VA

Sound volume: 120DB

Electric ringtone: beeping ringtone, uninterrupted sound

Electric flute sound: beep, uninterrupted sound

Working mode: Power on sounds, power off sounds silent

Dielectric performance

Isolation voltage: Input terminal to ground 3000V, 1 minute

Insulation resistance: > 100M Ω.

Anti interference capability: The product can withstand the electrical fast transient pulse group immunity test specified in Chapter 5 of GB/T 17626.4-2008, with a test level of 4.

Applicable environment: temperature -25~55 °C, humidity not exceeding 90% RH

average time between failures: not less than 50000h



3、 External dimensions and wiring

External dimensions: 72x72x75mm

Opening size: 68x68mm

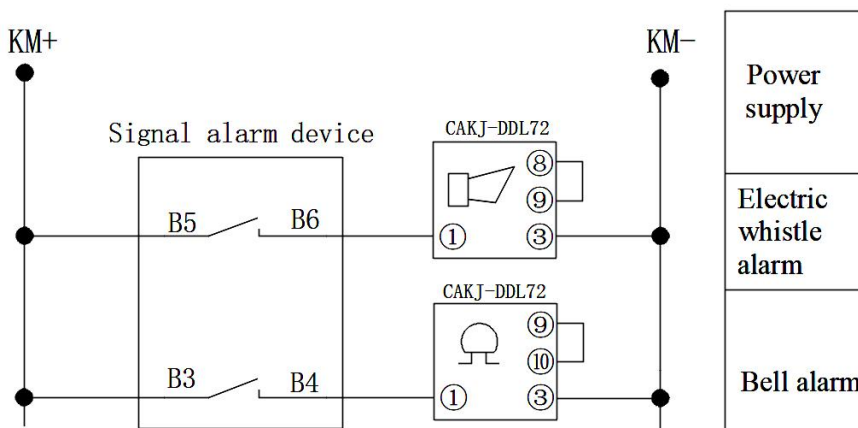
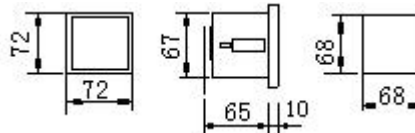

Terminal wiring diagram (back view)

4、 Ordering Notice

CAKJ-DDL72 Electric Bell and Horn can achieve alarm sound through external short circuit wiring. One set of two can achieve separate alarm of electric bell and horn.

CA-XXS-YX2 electronic audio system (optional)

1、 Overview

CA-XXS-YX2 electronic audio system is a low-power, non-interference, and high-volume electronic alarm device designed for central signal alarms in power systems. Using a microcontroller to simulate the frequency spectrum of electronic audio systems (fire and rescue sounds), electric horns, and electric bells, its sound is 98% similar to that of fire, rescue, electromagnetic bells, and electric horns. It has dual speakers and dual tones, and the tone volume can be adjusted.

2、 Technical parameters

Working power supply: AC, DC80-265V, wide voltage AC/DC universal, DC24V specified when ordering

Power consumption: not exceeding 5VA

Adjustable volume: 120DB high and 60DB low can be selected by pressing the "volume" button

Tone options: electronic sound system, electric bell and flute sound can be selected by pressing the "tone" button.

Alarm circuit: 2 signal inputs, accident sound contact and warning sound contact

Working mode: Turn on the signal to sound, turn off the signal to sound silently.

Sound test: Turn on the power, press the test button, both the accident and warning will sound simultaneously, and the indicator light will light up.

Indicator light: 6 LED indicators, power, test, tone, volume, accident, and warning

tone (not on - electronic sound, on - bell and whistle), volume (not on - low, on - high)

button: 3 buttons, test, tone, and volume

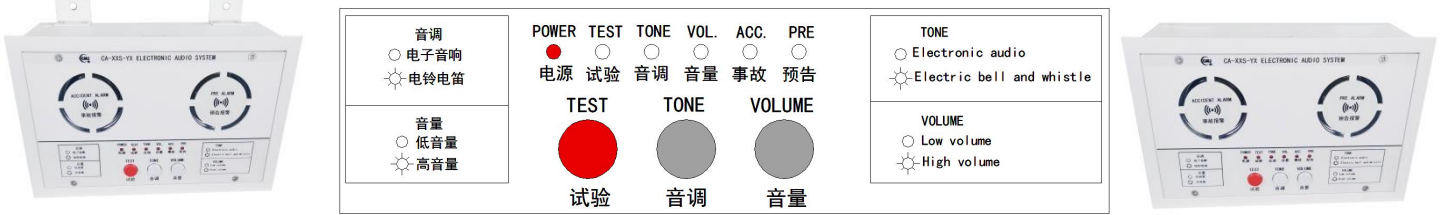

Dielectric performance

Isolation voltage: Input terminal to ground 3000V, 1 minute

Insulation resistance: > 100M Ω.

Anti interference capability: The product can withstand the electrical fast transient pulse group immunity test with a test level of 4 specified in Chapter 5 of GB/T 17626.4-2008

Applicable environment: Temperature -25~55 °C, humidity not exceeding 90% RH

Mean time between failures: not less than 50000h

3、 Installation and wiring

Fixed with brackets or suspended behind the disc with accessories for hole embedding

External dimensions: 210X135X92

Opening size: 202X127

System wiring diagram

